

**User Manual &
Spare Parts Catalogue**

(EN) 26-08-2024

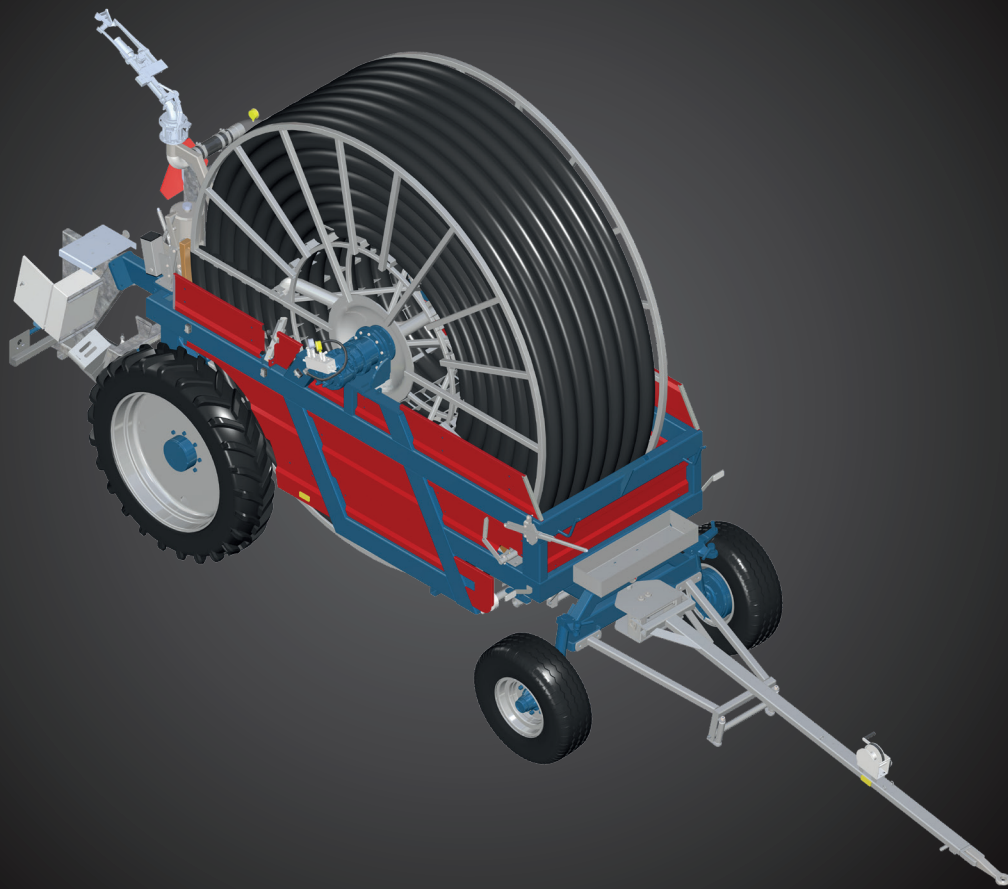

**Irrigator
FM4550H**



Fasterholt Maskinfabrik A/S
Ejstrupvej 22
7330 Brande
Denmark

Telephone:
Telefax:
E-mail:
Web:

+45 97 18 80 66
+45 97 18 80 40
mail@fasterholt.dk
www.fasterholt.dk

<u>EU Declaration of Conformity</u>	<u>3</u>
<u>General safety</u>	<u>4</u>
Operating instructions for Fasterholt FM 4550H	4
<u>Product labelling</u>	<u>5</u>
Symbols used in this product	5
<u>Operating instructions</u>	<u>6</u>
Starting the FM4550H	6
Preparing the machine for irrigation	6
Preparing the machine after irrigation	7
Maintenance	7
Preparation for winter	8
Faults on the Irrigator	8
<u>Technical data</u>	<u>9</u>
Nelson SR 150	9
<u>Guarantee and complaints</u>	<u>30</u>
<u>Spare parts</u>	<u>32</u>
Front axle and drawbar	32
Front axle	36
Cross track shaft	38
Guards	44
Guards updated 2023	46
Turbine	60
Stop bracket	66
Rear drawbar	68
Parts on Rear drawbar	70
Rear axle assembly	72
Rear axle parts	80
Hydraulics	82
Turbine installation	88
Gun	90
A-frame	94

EEC Declaration of conformity

Manufacture (name and address):

Fasterholt Maskinfabrik A/S

Adresse: Ejstrupvej 22,
Fasterholt
Ort: 7330 Brande
Country: Denmark
Web: www.fasterholt.dk

CVR: 58 83 28 12
TEL: +45 97 18 80 66
FAX: +45 97 18 80 40
E-Mail: mail@fasterholt.dk

Hereby is certified that the following product:

Description, ID/mark, type: Irrigator FM 4550H

Serial No. if any: _____

Notified body if any: _____

EEC-type certificate if any: _____

Harmonised standards if any: EN 908:1999+A1:2009.
DS/EN/ISO 12100:2011.
DS/EN/ISO 14120:2015.

Is made according to the announcement no.693 of 10. Jun 2013 that implements the DIRECTIV 2006/42/EC.

Name, title and signature of manufacture:

Date

Signature

!!! Important!!!
READ THIS MANUAL BEFORE USING YOUR
IRRIGATOR!!

Operating instructions for FASTERHOLT FM 4550H

Your new FASTERHOLT Irrigator is a Danish built machine, but even the best machines only deliver top results when they are properly used and maintained.

To ensure that the machine complies with the EU Machinery Directive, only original spare parts may be used. Otherwise, compliance will be lost and safety will be entirely at your own risk.

The irrigator is intended for irrigation with clean water from a drilled well or a watercourse.

1. Safety instructions/warnings!!

- It is forbidden to stand on the machine during irrigation and transport(**risk of fatal injury**).
- The guards are fitted for your own safety - please leave them in place.
- Remember to tighten the wheel bolts.
- When starting the machine on falling ground, you must be **VERY** careful not to disconnect the tractor from the machine until the machine has been put into gear, otherwise the machine may run away.
- If a rear wheel is removed, **THE MACHINE MUST BE JACKED UP AND VERY STABLE**, because if it overturns, it will fall completely on its side.

WARNING!!

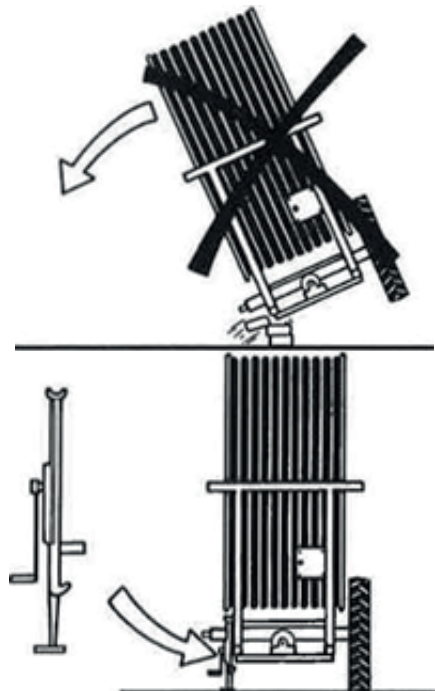

- To perform an EMERGENCY STOP, pull the cable for the miswinding bar or press STOP on the COMPUTER.
- V-belts may only be fitted after the machine has been unwound for the first time. (only the first time the machine is used for irrigation.)
- The gun must face out to the side when unwinding the machine.
- **STAND ASIDE** when the gun is operating.
- **WARNING** against contact with overhead power lines with the machine or water jet. Avoid irrigation on or near power lines.
- During transport on uneven roads/fields, move **VERY** carefully according to the conditions.
- Max. transport speed with water in the hose is 15 km/h.
- When parking the machine, use the wheel chocks mounted by the rear wheels.
- **DANGER!!** Avoid welding in the paint layer! Before welding, remove all paint from the welding area
- Avoid inhalation of grinding dust.
- Hydraulic oil can be harmful to health:
- Skin contact may cause allergies.
- Inhalation of oil mist may cause lung disease.
- Leakage of oil under high pressure is dangerous, an oil jet can enter the skin, eyes, etc.
- If a hydraulic system leak is found, stop the system immediately and rectify the fault.
- Note that due to operation, the oil may be 70 degrees Celsius or even hotter. This can lead to a risk of scalding during separation.
- **IMPORTANT** Maximum battery charging power is 2 amps. Charging more than 2 amps may cause the battery to crack. The battery must be charged at a temperature between 0 °C and +40 °C. NEVER place the battery in a sealed container while charging. During winter, the battery must be removed and stored in a dry place indoors in a fully charged state.
- Avoid sparks and flames on and around the battery.
- Do not short circuit the battery.
- Never disassemble the battery.
- If you come into contact with the battery's sulphuric acid, wash immediately with water. If acid comes into contact with eyes, rinse thoroughly with water and seek medical attention immediately.
- Pay attention to the battery compartment. If there are cracks, deformities, electrolyte leakage, etc., replace the battery immediately.
- If the battery is dirty, clean it as soon as possible.
- Disposal of oil spills:
- If oil spills are found, they should be cleaned up immediately with rags or oil absorbent powder.
- Spilled products, as well as rags and powder used for oil spills, must be stored in sealed metal containers and delivered to the municipal collection site.
- Batteries, hoses, tyres and other parts of the irrigation machine must be disposed of at an approved recycling site.

If the machine is to be moved via public roads, it must first be drained of water.

Symbols used in this product

The following symbols are used in this product and the following documentation.



WARNING Indicates a potentially dangerous situation which, if not prevented, could result in death or serious injury.



LUBRICATION Indicates lubrication is required as per the service description.



SERVICE WARNING Indicates a service hazard

Starting the FM4550H

Move the machine to the field in the transport position. When the machine is at the crop to be irrigated, disconnect the tractor from the front drawbar. Connect the tractor to the rear drawbar. Insert the electric brake connector in the female connector for the tractor lights. The machine then winds up in the crop and stops.

Disengage the stop pawl at the hose drum.

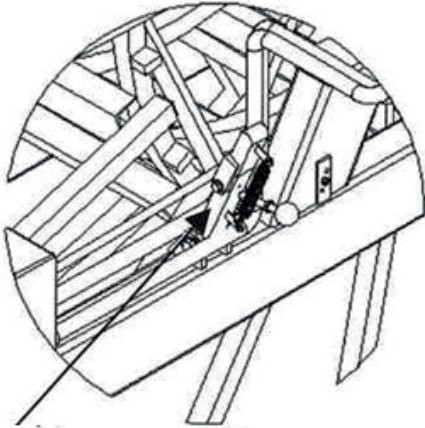

The stop pawl at the hose reel is disengaged when laying the hose.

Remember!! When starting the machine on falling ground, you must be **VERY** careful not to disconnect the tractor from the machine until the machine has been put into gear, otherwise the machine may run away.

Safety stop

During irrigation



During transport

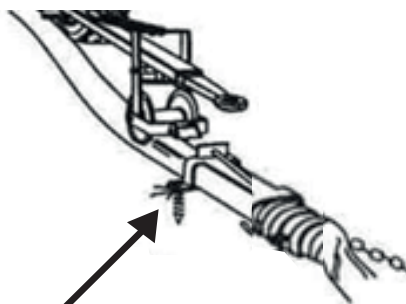

Ground spike

Secure the drawbar with the long ground spikes. Lower the drawbar over the hose and release the safety stop so the hose reel runs on the hose.

Unwind the machine at **max. 5 km/h** to keep the hose tight on the drum at all times with the electric brake. If you do not lay the hose straight out be **very careful** to ensure that the hose is always tightened on the hose drum.

The machine should be unwound completely at least every 3rd time.

Before starting to unwind the machine, reset PROGRAM RAIN. To do this, press the TOGGLE SWITCH located on the side of the electric box upwards (reset).

When unwinding the machine, the TOGGLE SWITCH must be in the centre (unwind) so it cannot reset on the way out. After unwinding, press the TOGGLE SWITCH down (operation).

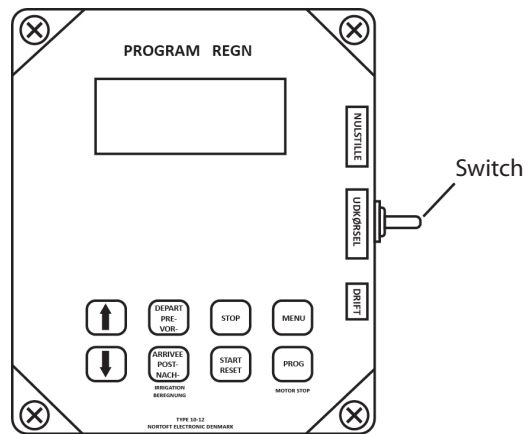

ALWAYS REMEMBER that the TOGGLE SWITCH must be pressed down during operation, otherwise the machine will not move.

Preparing the machine for irrigation

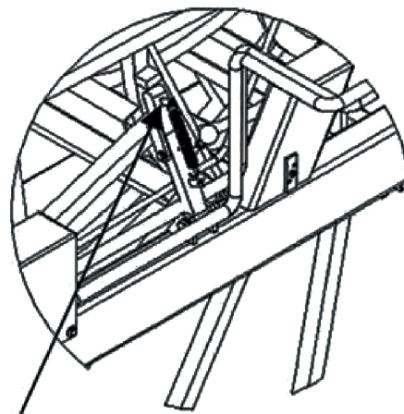

Disengage the stop pawl at the hose to enable operation. Also remember to release the electric brake and disconnect the electric brake connector from the tractor.

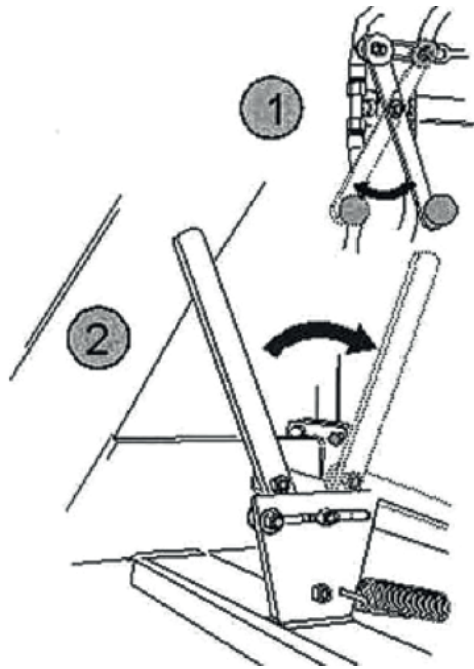

Remember to close the decoupling valve (**Lever "1" must be pulled out**) and to engage with the coupling lever. (**Lever "2" pulled out**)

Attach the charge hose to the hydrant. Then open the hydrant, start the pump and irrigation can begin.

When starting irrigation, see the operating instructions for PROGRAM RAIN.

Put the machine in gear. (Remember to select the right gear for the speed you want to drive at.) (Refer to table below or on the machine for electrical control.)

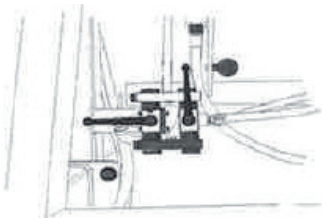

1.GEAR
20-30 meter
pr. time

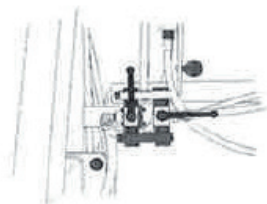

2.GEAR
30-45 meter
pr. time

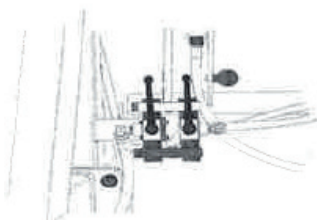

3.GEAR
45-90 meter
pr. time

Preparing the machine after irrigation

After each irrigation, open the bypass valve (**Lever "1" must be pushed in**) to get the gearbox out of gear (**Lever "2" pulled out**). If there is tension in the rear axle assembly, use a fork wrench to turn the input shaft to release the coupling.

ALWAYS REMEMBER THAT THE COUPLING MUST BE RELEASED (COUPLING LEVER PULLED BACK) WHEN THE MACHINE IS NOT MOVING BY ITSELF.

Maintenance

1x per week:

Check that no water is entering the oil on the rear axle assembly and hydraulic system.

Lubricate the steering, roller chain for hose guides, roller chain for forward traction, cross track shaft for hose guide with water-repellent grease.

Check tyre pressure:

Rear wheel air pressure: FM 4550H: 2.9 bar

Front wheel air pressure: FM4550H: 4.1 bar
FM4550H: 3.6 bar (TR)

Check that front and rear drawbars line up.

Clean the filter at the turbine outlet if required

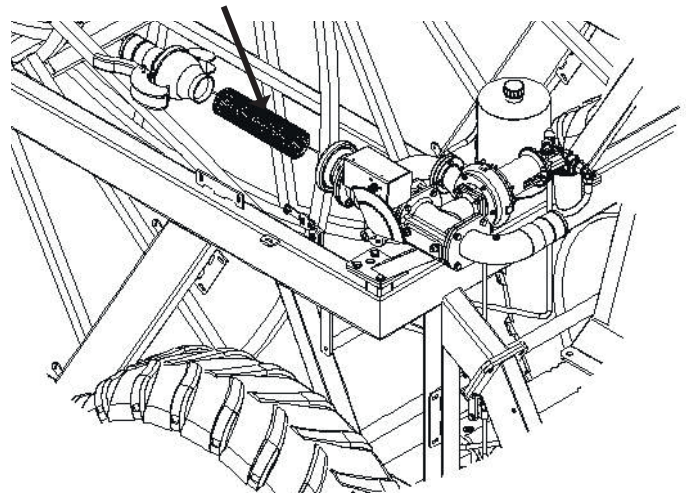

Check that the hose is positioned neatly on the hose drum. Remember to check the guide pins in the hose guides regularly.

Remember to tighten the wheel bolts regularly.

Tighten rear wheel bolts to: 360 Nm

Tighten front wheel bolts to: 330 Nm

NOTE:

The battery should be charged once a month during the season to maintain full power and extend its useful life.

Preparation for winter

Drain water from the machine:

Water can only be drained from the machine with air. Use the special compressor for draining.

REMEMBER!!

Open the filter coupling.

Open the valve in the base of the turbine

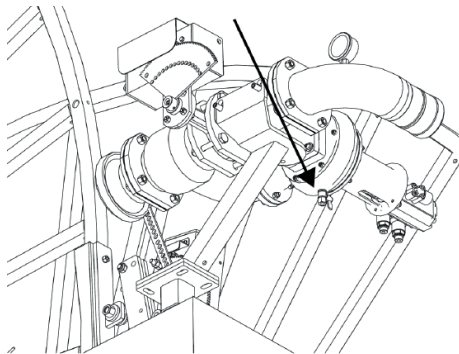

On machines with high pressure stops START to open the main valve and allow the water to flow out freely. (Disconnect battery lead so stop valve does not close again.)

Remove the battery and do not install it until the next time you use the machine.

Lubrication of:

Front wheel hubs, front spindle, hose guides, bearings on hose guides, wheels.

Check for water in the oil in the rear axle assembly and hydraulic tank. Oil in the rear axle assembly / flat gear should be changed every 1,000 hours. Hydraulic oil and filter should also be replaced every two years.

Lubricate the steering, roller chain for hose guides, roller chain for forward traction, cross track shaft for hose guide with water-repellent grease.

Check tyre pressure:

Guide pins should be replaced every year.

Faults on the Irrigator

Check the following before calling a technician:

1. If the machine is irrigating, but not moving:
 - a. Check that machine is in gear.
 - b. Check if it is performing pre-irrigation or post-irrigation. (can be seen on the display under menu 3.)
 - c. Check if pressure drop valve is closed.
 - d. Check that end stop sensor is in place. (Can be seen on the display under menu 2.)
 - e. Check that toggle switch is in operation position.

- f. Check that decoupling valve is closed (for hydraulic motor)
- g. Check that filter at turbine outlet is not blocked.
- h. Check that turbine can turn easily.

2. If the machine does not wind up the hose properly, it may be that:
 - a. The hose guide needs to be adjusted:

To adjust the guide, remove the chain from the hose guide to the cross track shaft. Then turn the cross track shaft until the hose guide fits the hose again. Then fit the chain.
 - b. The guide pin is worn and needs to be replaced.
 - c. There is not enough pressure on the drum winder. (call a technician).
3. Front and rear forced steering are not aligned and forced steering is sprung on impact:
 - a. There is a leak at the coupling or assemblies, so the oil has drained out, leaving air in the system.
 - b. The system must be vented. (call a technician).

Nelson SR 150 is factory-adjusted to Danish conditions and ready to use after the following three steps:

1. Select and install the nozzle size that best suits your application. Performance data for the different sizes are shown in the table below.
2. Adjust the stop on the part circle to obtain the desired irrigation angle.
3. There is a grease nipples which should be checked once a week for refilling.

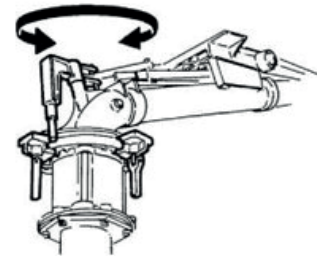

ADJUSTMENT

The only thing you can adjust is the counterweight on the drive arm. By moving the counterweight forward, the gun will slowly irrigate from side to side. If you move the counterweight back, the gun will irrigate quickly. If it does not irrigate quickly enough, you can remove the brake springs (no. 778474) in pairs (contact the service department).

WARNING: DO NOT ADJUST WHEN THE GUN IS IRRIGATING!!

DANGER.....: HIGH WATER PRESSURE – STAY CLEAR!!

TABLE FOR NELSON SR 150

Dysetabel for Nelson SR150 kanon, 21°- Plastdyser.

Tryk (Bar)	18mm		19mm		20mm		21mm		22mm		23mm		24mm	
	m ³ /h	Rad.(m)	m ³ /h	Rad.(m)	m ³ /h	Rad.(m)	m ³ /h	Rad.(m)	m ³ /h	Rad.(m)	m ³ /h	Rad.(m)	m ³ /h	Rad.(m)
3,5	20,2	32,5	22,7	33,5	25,4	34,5	28,0	36,0	30,9	36,5	34,1	37,5	37,5	38,8
4,0	21,6	33,5	24,3	34,5	27,1	35,7	29,9	36,5	33,0	37,8	36,4	38,8	40,1	40,0
4,5	22,9	34,5	25,7	35,7	28,7	36,5	31,7	37,8	35,0	39,2	38,6	40,5	42,5	41,4
5,0	24,2	35,2	27,1	36,5	30,3	37,8	33,4	39,2	36,9	40,5	40,7	41,4	44,8	42,7
5,5	25,3	36,5	28,5	37,8	31,7	38,7	35,1	40,0	38,7	41,4	42,6	42,7	47,0	44,0
6,0	26,5	37,4	29,8	38,7	33,1	40,0	36,6	41,4	40,4	42,7	44,5	44,0	49,0	45,3

Tryk (Bar)	25mm		26mm		27mm		28mm		29mm		30mm		31mm	
	m ³ /h	Rad.(m)	m ³ /h	Rad.(m)	m ³ /h	Rad.(m)	m ³ /h	Rad.(m)	m ³ /h	Rad.(m)	m ³ /h	Rad.(m)	m ³ /h	Rad.(m)
3,5	41,0	39,6	44,8	40,5	49,0	41,8	53,3	42,7	57,9	44,0	62,8	44,8	67,8	45,8
4,0	43,8	40,9	47,8	42,2	52,3	43,1	57,0	44,5	61,9	45,8	67,1	46,6	72,5	47,5
4,5	46,5	42,7	50,7	43,6	55,5	44,5	60,5	45,8	65,7	47,0	71,2	48,0	76,9	49,3
5,0	49,0	44,0	53,5	44,5	58,5	46,2	63,8	47,5	69,2	48,4	75,1	49,7	81,1	50,6
5,5	51,4	44,5	56,1	46,2	61,4	47,5	66,9	48,8	72,6	50,2	78,7	51,0	85,0	52,4
6,0	53,7	46,2	58,6	47,5	64,1	48,8	69,9	49,7	75,8	51,0	82,2	52,4	88,8	53,7

Tryk (Bar)	32mm		33mm		34mm	
	m ³ /h	Rad.(m)	m ³ /h	Rad.(m)	m ³ /h	Rad.(m)
3,5	73,1	46,6	78,7	47,5	84,5	48,4
4,0	78,1	48,4	84,2	49,3	90,3	50,2
4,5	82,9	50,2	89,3	51,0	95,8	51,9
5,0	87,4	51,9	94,1	52,8	101,0	53,2
5,5	91,6	53,2	97,8	54,1	105,9	55,0
6,0	95,7	54,6	103,0	55,4	110,6	56,3



Hose PEMD 100 mm:
Capacity up to 55m³ - hose length from 500 to 675 m.

Hose PEMD 110 mm:
Capacity up to 75 m³ - hose length from 350 to 550 m.

Wheel size:

Rear wheels: 12.4"x36" x 10 ply - air pressure: 2.9 bar

Front wheels: 13.0"/75x16" x 10 ply - air pressure: 4.1 bar
15.0"/55x17" x 10 ply (TR) - air pressure: 3.6 bar

Speed at 35 m³ and above:

10-80 metres per hour

Weight of standard FM 4550H

Weight with water with 675 m. 100 mm hose:	4381 kg.
Weight without water with 675 m. 100 mm hose:	7950 kg.
Track width (Standard):	1850 mm.
Can be ordered with:	2010 mm
Gun:	Nelson SR 150
Oil in rear axle assembly.....:	16 litres 80/90 gear oil Track width 1850 mm.
Oil in rear axle assembly.....:	18 litres 80/90 gear oil Track width 2010 mm.
Oil in flat gear...:	1,5 litres 80/90 gear oil
Hydraulic oil.....:	10 litres STATOIL Hvxa 46
Grease for lubrication	FUCHS Greaseway CAH 92 or equivalent.
Width	230 cm.
Length without drawbar	595 cm.
Height	370 cm.
Total length	825 cm

Changing the Oil	First Use	Use Routine Maintenance
Axle oil change	200 H	Seasonal/every. 1000 H (1)
Cleaning of magnetic oil drain plug	At first oil change	At each oil change
Check and refill oil	100 H	Monthly/every 300 H (1)
Cleaning of oil vent	400 H	Monthly/every 300 H (1)
Lubrication (where intended)	200 H (2)	Weekly/every 200 H (1)(2)

(1) = Which of the two conditions occurs first

(2) = 50 Hours in case of hard work

H = Hours

Contact the Sales Department at Fasterholt Maskinfabrik A/S if there are any questions.

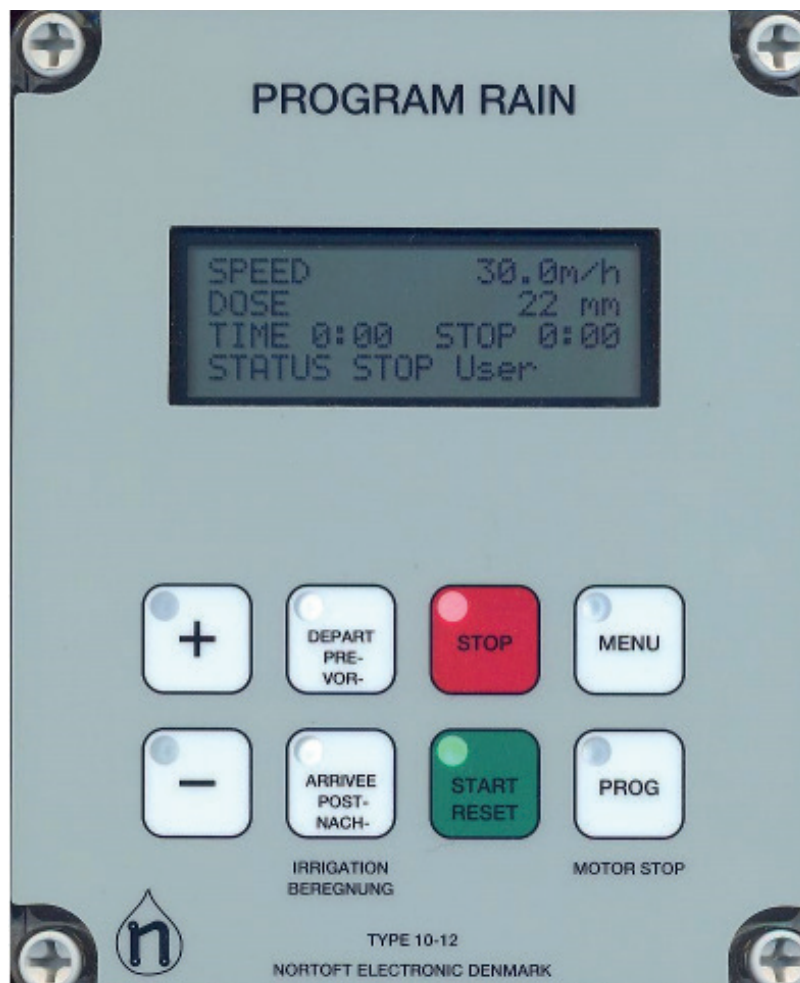
**Functions:**

Speed regulator
 Pre- and Post-irrigation
 4 different speeds on sections of the lane
 Clock
 Setting the start time
 Stop time is shown on the display
 Length of hose
 Current speed
 Battery volts
 Charge regulator

Pressure sensor

Stop sensor

Speed sensor

Motor 1, regulating motor

Motor 2, stop motor

Slow start of turbine

Slow opening of inlet

Water volume + spreading width

Accessories:

GSM, SMS messages for remote control.

Analogue pressure sensor.

Short instructions for use



Speed	30.0m/h			
Dose	22 mm			
Time	7:28	STOP	7:28	
STATUS STOP Sensor				
Speed	30.0m/h			
Dose	22 mm			
Time	7:56	STOP	17:16	
STATUS STOP Sensor				
Speed	25.0m/h			
Dose	26 mm			
Time	7:58	STOP	17:58	
STATUS STOP Sensor				
Speed	25.0m/h			
Dose	26 mm			
Time	7:58	STOP	17:58	
STATUS STOP Sensor				
Speed	25.0m/h			
Dose	26 mm			
Time	8:00	STOP	18:38	
STATUS Running				
Speed	25.0m/h			
Dose	26 mm			
Time	8:02	STOP	18:38	
STATUS PRE Irri.				
Speed	25.0m/h			
Dose	26 mm			
Time	18:20	STOP	18:38	
STATUS POST Irri.				
Speed	25.0m/h			
Dose	26 mm			
Time	18:38	STOP	18:38	
STATUS STOP Sensor				

Place Machine:

Move machine to a new lane. Display shows start and stop time. Pull hose out to end of the lane. (e.g. 250 m)

Select Speed:

Display now shows stop after 9h 20m. Press the "+" or "-" key to set the speed. Speed can be adjusted during irrigation.

SPEED has decreased, DOSE has increased and STOP time is later.

Start Irrigate, Select PRE- and POST Irrigation:

Press START to start. Press PRE and POST for pre- and post-irrigation respectively. STOP time will be later when PRE and POST irrigation are selected.

Starting

The turbine will start when the water pressure increases. After a short period, the regulator finds the correct speed. Irrigation continues until STOP SENSOR is activated at the end of the lane.

PRE Irrigation:

If pre-irrigation is selected, the turbine stops immediately after performing a start and pre-irrigation. When the pre-irrigation time has elapsed, the turbine starts and the machine changes status to Irrigating.

POST Irrigation:

If post-irrigation is selected, the turbine stops at the end of the lane when the stop sensor is activated. Post-irrigation then starts.

Stop:

Stop sensor is activated, turbine and water are shut off. The machine is now ready to be moved to a new lane.

General instructions for use

SPEED	30.0m/h		
DOSE	22 mm		
TIME	7:28	STOP	7:28
STATUS	Running		
ZONE 1	30.0m/h		
DOSE	22 mm		
TIME	7:56	STOP	17:16
STATUS	Running		
DISTANCE	123m		
DOSE	12.8V		
CHARGE	ON	0.231A	
PRE	0:45	POST	0:45
PRESS	SENSOR		■
STOP	SENSOR		■
SPEED.	SENSOR		■ ■
MOT1	0.0A	MOT2	1.8A
A.SPEED	22m/t		
START	0:00		
STOP	7:43		
WORKING HOURS	123t		
0m	30.0m/h	0m	
0m	30.0m/h	0m	
0m	30.0m/h	0m	
0m	30.0m/h	0m	
SIGNAL 23			
NETWORK HOME			
A:	+45123456		
B:	+45123456		

Standard display

Standard display, ZONE irrigation is selected.

Press the **MENU key 1 time to display menu 2**

Press the **MENU key 2 times to display menu 3**

Press the **MENU key 3 times to display menu 4**

Press the **MENU key 4 times to display menu 5**

Press the **MENU key 5 times to display menu 6**
(Only if GSM is selected)

When ■ appears in the display, this indicates that the relevant function is ON.

Standard menu:

SPEED	30.0m/h
DOSE	22 mm
TIME	14:10 STOP 7:28
STATUS	Running

- SPEED** Speed. Can be changed at any time during irrigation using the "+" and "-" keys.

- ZONE** Current zone 1...4, with corresponding speed. The speed cannot be changed. (Zone active)

- DOSE** The dose is calculated from the speed and constants and shows the current number of mm for irrigation. As SPEED increases, DOSE decreases. (Constants 11 and 12)

- TIME** To set the time: Set SPEED to 11.1 m/h and press the **PROG** key 3 + 1 times until the display shows <CONST 1 TIME>. The time can then be set with the "+" and "-" keys. When the battery has been disconnected, the clock will show 0:00 until it is set again.

- STOP** The time that irrigation is completed, incl. pre- and post-irrigation. If the clock is not set and shows 0:00, the total irrigation time is displayed..

- STATUS** Irrigation status, e.g.:
 - < Stop Sensor >
 - < Irrigating >
 - < Pre-irrigating >
 - < Post-irrigating >
 - < LOW pressure >
 See explanation in STATUS chapter.

If the display shows: **LOW BATTERY** instead of SPEED, the battery voltage is below 11.8 V and the battery needs to be charged.

MENU 2

DISTANCE	123m
DOSE	12.8V
CHARGE ON	0.231A
PRE	0:45 POST 0:45

- DISTANCE Length of the unwound hose. The length can be changed immediately after pressing the **PROG** key 3 times, using the "+" and "-" keys.

- BATTERY Battery voltage.

- CHARGE ON Shows when the battery is being charged by a solar cell. The battery is charged when the voltage is below 14.0 volts.

- PRE Shows the pre-irrigation time.

- POST Shows the post-irrigation time.

The pre- and post-irrigation times can be changed immediately after pressing the PRE- or **POST**- keys, using the "+" and "-" keys.

MENU 3

PRESS	SENSOR		■
STOP	SENSOR		■
SPEED.	SENSOR		■ ■
MOT1	0.0A	MOT2	1.8A

PRESSURE SENSOR

Shows that the pressure is high when block is lit. **The machine can only move when the pressure is high.** If no pressure sensor is fitted (machine data 14 = 0), the machine will move regardless of pressure status.

The machine can be fitted with analogue pressure sensors. Sensors must be connected according to the diagram. Pressure sensor functions, except for pressure display, are the same as for digital pressure sensors. There are constants for the pressure sensor type. Similarly, set point and hysteresis can be selected for each machine.

PRESS			6.2	■
STOP	SENSOR			■
SPEED.	SENSOR			■ ■
MOT1	0.0A	MOT2	0.0A	

Shows pressure in [BAR] (00.0) or [PSI] (000). Pressure is high when ■ is lit.

The machine can only move when the pressure is high.

If no pressure sensor is fitted (machine data 14 = 0), the machine will operate regardless of pressure status.

PRESS			--	■
STOP	SENSOR			■
SPEED.	SENSOR			■ ■
MOT1	0.0A	MOT2	0.0A	

STOP SENSOR

Shows that the magnet is aligned with the stop sensor when block is lit.

The machine can only start when the magnet is aligned with the stop sensor.

The stop sensor has 3 functions:

1. Reset distance.
2. Post-irrigation.
3. Stop pulses to the regulator motor.

SPEED SENSOR

For the speed sensor test, block is only lit when the magnet passes the sensor.

MOT1, MOT2

Displays the current motor current. When the current exceeds 4.5 A, the motor stops.

If the current exceeds 4.5 A and the valve is not in the outer position, there may be a blockage in the valve.

MENU 4

ACTUAL SPEED	22m/h
START	0:00
STOP	7:43
WORKING HOURS	123t

- CURR. SPEED** Shows the current speed. That is, the speed at which the machine is moving now. This can be used to find how fast the machine can move. The current speed may differ slightly from the set speed, especially at the start. This does not matter, as regulation ensures that the average speed within 10 metres is correct.
- START** Start machine delay. The machine start time can be delayed by up to 24 hours. To set the start time, press the **PROG** key 3 times, then set the time using the "+" and "-" keys.
- STOP** The time that irrigation is completed with a delayed start.
- OPERATING HOURS** Shows how many hours the machine has been running since the electronics started for the first time.

MENU 5

0m	30.0m/h	0m
0m	30.0m/h	0m
0m	30.0m/h	0m
0m	30.0m/h	0m

This menu is for irrigation at different speeds in zones of the lane.
 Press the **PROG** key 3 times to program the zones.
See later chapter for details.

MENU 5

SIGNAL 23
NETWORK HOME
A: +45123456
B: +45123456

SIGNAL GSM signal strength.
 NETWORK GSM network
 A: First number on "SMS" list.
 B: Second number on "SMS" list.

See GSM chapter for details.

START:

The turbine can only start if the magnet is aligned with the end stop sensor (or end stop sensors). See menu 3 for control of the STOP SENSOR. Press the **START** key to turn on the water. The regulator valve for bypass around the turbine then closes. (Turbine starts). If the end stop sensor is not in place, only the main valve can be opened, which then immediately closes again. Used to relieve pressure before removing charge hose from hydrant.

DEFERRAL OF START TIME

First press the **STOP** key to shut off the water. Then press the **MENU** key 3 times and **PROG** 3 times. The start time can be set using the "+" and "-" keys. Finally, select pre- and post-irrigation. To exit, press **MENU**. Info: The clock can only be set forwards.

STOP:

When the magnet is removed from the end stop sensor, the turbine stops and the main valve shuts off the water (turns on the water at negative pressure). If post-irrigation is selected, rewinding stops when the magnet is removed from the sensor. When the post-irrigation time has elapsed, the main valve closes. When the **STOP** key is pressed, the turbine stops immediately and the main valve shuts off the water, regardless of whether post-irrigation is selected.

SUPERVISION:

Program Rain has a built-in supervision system. The supervision system will be activated if for any reason the machine has water in the same location for longer than a specified time. This time is factory-set to 20 minutes. If the time is set to 0, there is no supervision. (See constants on page 17 for setting the supervision time.) If speed supervision less than 50 % of pre-selection is required, select speed supervision together with the above time.

SPEED:

The speed is set using the "+" and "-" keys. First count up in steps of 0.1 m/h. After 10 steps, count up in steps of 1 m/h. The speed can be changed at any time during irrigation. If the speed changes during irrigation, the dose and time for the remaining irrigation will be calculated immediately based on the new speed.

PRE-IRRIGATION:

If pre-irrigation is required, press the **PRE-** key. The pre-irrigation time is calculated as 8 x the time to move 1 m at the current speed. The constant can be changed individually for pre- and post-irrigation. (See constants). If pre-irrigation is selected, the machine will move forward approx. ½ m, after which the machine will stop and stand still for as long as pre-irrigation is performed. Menu 2 shows the number of minutes remaining of the pre-irrigation time. If you want to cancel pre-irrigation, press the **START** key. This will cancel both pre- and post-irrigation and the turbine will start.

POST-IRRIGATION:

If post-irrigation is required, press the **POST-** key. The post-irrigation time is calculated as 8 x the time to move 1 m at the current speed. The constant "8" can be changed individually for pre- and post-irrigation. (See constants on page 16). Post-irrigation starts counting down when the magnet is removed from the stop sensor. When the stop sensor is activated, the turbine stops and post-irrigation starts counting down (see menu 2). When the post-irrigation time has elapsed, the main valve closes. (Opens in installations with negative pressure stops). For machines with mechanical end stops: The turbine stops when the stop sensor is activated. When the post-irrigation time has elapsed, the turbine starts and the machine moves to the mechanical end stop. Press **START** to cancel post-irrigation. If constant "8" (early stop) is selected, the machine will stop when it reaches the selected distance.

PROGRAMMING 4 DIFFERENT SPEEDS:

The hose must be unwound before programming, so the computer knows the number of metres in the irrigation lane. The following example assumes that the unwound hose is 400 m. Press the **PROG** key 3 times and the display will show:

400m	30.0m/h	0m
0m	30.0m/h	0m
0m	30.0m/h	0m
0m	30.0m/h	0m

The desired speed can now be selected, in this case 25.0 m/h. Press the **PROG** key and the display will show::

400m	25.0m/t	0m
0m	30.0m/h	0m
0m	30.0m/h	0m
0m	30.0m/h	0m

The desired distance can now be selected, in this case 300 m. Press the **PROG** key and the display will show:

400m	25.0m/t	300m
300m	30.0m/h	0m
0m	30.0m/h	0m
0m	30.0m/h	0m

Now that the first zone is programmed, apply the same procedure to all 4 zones. Zone 4 automatically ends at 0. When zone 4 is programmed, press the **PROG** key again and the display will show:

DELETE	PRESS	MENU
SAVE	PRESS	PROG

If **PROG** is pressed, the program is stored and irrigation will be performed according to this program.

If **MENU** is pressed, the program is deleted and the speed is the same for the entire irrigation lane.

STATUS	Status messages in display
RUNNING	Machine has not been started, anyway speed pulses is received and it is trying to maintain the speed requested.
RUNNING:	The machine is irrigating, and everything is working properly.
LOW PRESSURE:	Water pressure is below pressure switch treshold. Machine acts depending on Machine data.
STARTING:	Operator has pressed START key, and start sequens is in process.
START REMOTE:	Machine is starting due to an SMS .
START DELAY:	Machine is waiting for start delay to elapse. (See menu 4).
START PRESSURE:	Machine has started due to pressure rise. Machine is using pressure level, to start 2'nd machine on string.
START DENIED:	Operator is holding STOP key to prevent PRESSURE and REMOTE start.
STOP USER:	Machine has stopped due to operator STOP .
STOP REMOTE:	Machine has stopped due to an SMS .
STOP SENSOR:	Machine has reached end and is stopped by STOP SENSOR .
STOP DISTANCE:	Machine has reached distance for stop. (See constant for early stop).
STOP DELAY:	Machine has reached stop but waits nn Seconds to proceed stop sequence.
STOP DENIED:	Operator is pressing START key, preventing REMOTE stop.
SUPERVISION TIME:	Machine has stopped due to supervision time is elapsed. Machine has not moved in nn minutes. (See constant for supervision time).
FORCE LOW PRES:	Machine opens valve, to force pressure drop, to stop main pompe. After 2 minutes, valve closes to prevent draining of pipes.
PRE IRRIGATION:	Machine is performing pre irrigation
POST IRRIGATION:	Machine is performing post irrigation

There are a variety of constants that can be modified by the user.

These constants will be stored for many years, even if the battery is removed.

Programming procedure:

Adjust the speed to 11.1 m/h to access the constants.

Press the **PROG** key 3 times in quick succession to access and change the constants.

Press the **PROG** key again to count forward to the constant you wish to change.

Press "+" and "-" to adjust the value of the constant.

Press the **MENU** key to save the change and the display will return to normal.

If the **MENU** key is not pressed, the display will return to normal after 1 minute and the change will not be saved.

CONSTANTS

Cons no.	Note	Fact. Adj.	Min. Value	Max. Value	Description
0		100	-	-	Enter 111 to reach machine data
1		00:00	00:00	23:59	Time in line 2 is set
2		8	1	15	Pre irrigation
3		8	1	15	Pre irrigation
4		20	0	99	Supervision time [minutes]
5		1	1	15	1 English, 2 Danish, 3 German, 4 French, 5, Dutch 6 Swedish, 7 Spanish, 8 Italian, 9 Polish, 10 Japanese 11 Hungarian
6		0	0	2	0 = Stop for high pressure slow shutdown 1 = Stop for low pressure. valve opens and close again after 3 minutes 2 = Motor for stop disconnected
7		-	0	1000	Actual distance, can be set by the keyboard [m]
8		0	0	1000	Early stop [m] (* Is only performed when Post Irrigation is selected *)
9		0	0	1000	Post irrigation before stop [m]
10		0	0	1000	Distance for alarm [m] (* Disabled if Machine data 22. Sprinkler, is selected *)
11		40	5	120	Water flow [m3/h]
12		60	5	100	Spacing between irrigation lanes [m]

Set Constant no. 0 to 111 to set the machine data.

Then press **PROG** to display the machine data.

Machine data Number of flashing digits		Possible setting	Factory settings
0	Hose length	0 - 1,000m	Not used
1	Hose diameter	40 - 200 mm	Not used
2	Hose drum int. Diameter	500 - 3,000 mm	Not used
3	Number of hose turns per layer	5.00 - 30.00	Not used
4	Large gear on hose drum	50 - 1000	Not used
5	Small gear on gearbox	5 - 40	Not used
6	Number of magnets	1 - 20	Not used
7	Ovality compared to 100 %	0.70 - 1.00	Not used
8	Length of first pulse to stop valve	0 - 45 sec.	3
9	Length of subsequent short pulses to stop valve	0 - 300 m/sec.	160
10	Time between short pulses to stop valve	1 - 5 sec.	2
11	Number of short pulses to stop valve	0 - 250	100
12	Mechanical stop (with only 1 motor) Electrical stop (closed low pressure) even if the pressostat registers low pressure	0 1	1
13	Length of pulse to regulator motor at start-up (Oil pump Motor 1)	26.1 - 0.9 sec.	4.5
14	Pressostat not connected Pressostat connected (to start/stop) or Radio start Pressostat installed: (can be used (for start only) for 2 machines on the same system, Autostart with special pressostat.)	0 1 2	1
15	Length machine moves per pulse: 0 = Moves according to formula FM4300 & FM4300H = 73.5 mm (2 magnets) FM4300 & FM4300H = 38.8 mm (4 magnets) FM4400 & FM4400H = 46.2 mm (4 magnets) Old Rear axle assembly FM4400 & FM4400H = 46.0 mm (4 magnets) New Rear axle assembly FM4500 & FM4500H = 85.0 mm (2 magnets) FM4500 & FM4500H = 42.5 mm (4 magnets) FM4550 & FM4550H = 46.2 mm (4 magnets) Old Rear axle assembly FM4550 & FM4550H = 46.0 mm (4 magnets) New Rear axle assembly FM4800H = 43.3 mm (4 magnets) Old Rear axle assembly FM4800H = 46.0 mm (4 magnets) New Rear axle assembly FM4900H = 103.0 mm (2 magnets) FM4900H = 51.5 mm (4 magnets) FM4900H = 46.8 mm (4 magnets) New Rear axle assembly FM5500H = 47.0 mm (4 magnets) FM5500H = 47.0 mm (4 magnets) New Rear axle assembly 62.5 = When moving with roller Ø80 [mm] 0 = Moves according to formula (with data number 0 to 7)	0 - 160.0 mm	
16	Speed sensor 0 = Round sensor for roller 1 = Double sensor	0 1	1
17	Opening of inlet valve 0 = Quick opening 1 = Slow opening	0 1	0
18	Pressostat 0 = Inlet remains open at low pressure 1 = inlet closes at low pressure	0 1	0
19	Delay from stop sensor to turbine stopping (sec)	0	0

Cons no.	Note	Fact. Adj.	Min. Value	Max. Value	Description
40		0	0	2	Analog Pressure gauge 0 = Digital Switch 1 = Analog Pressure gauge - Display units [BAR] 2 = Analog Pressure gauge - Display units [PSI]
41		0.50	0.10	5	Voltage Offset [V]
42		0.20	0.05	5	Voltage gain [V]
43		3.5	0.0	25.0	Pressure setpoint 0.0 - 25.0 [BAR] Pressure level for Off - On
44		0.2	0.2	25.0	Pressure hysteresis 0.2 - 25.0 [BAR] * Setpoint - 0.5 * hysteresis for Off Setpoint + 0.5 * hysteresis for On Default Settings 0.2 • 3.4 BAR = Off • 3.6 BAR = On

Program Rain can be set to 2 different types of sensors.

See Machine Data #16 Sensor

One is a round sensor with 4 built-in sensors and can only be used for rollers with 1 magnet. When the battery is connected, the display shows the following for 2 seconds: **VERSION n.n0.**

The other is a rectangular sensor with 2 built-in sensors (double sensor). This is used for scanning on rollers with more than 1 magnet and for discs with from 1 to 20 magnets. When the battery is connected, the display shows the following for 2 seconds: **VERSION n.n1.**

Cable connection

Program Rain 10 version n.n1 = double sensor Cable connection				Program Rain 10 version n.n0 = round sensor Cable connection			
1	+ Battery	Brown	12V	1	+ Battery	Brown	12V
2	- Battery	Blue		2	- Battery	Blue	
3	+ Solar panel	Brown		3	+ Solar panel	Brown	
4	- Solar panel	Blue		4	- Solar panel	Blue	
5	Motor 1	Speed Regulation		5	Motor 1	Speed Regulation	
6	Motor 1	Speed Regulation		6	Motor 1	Speed Regulation	
7	Speed sensor 1	Blue	*	7	Speed sensor 1	Blue	*
8	Speed sensor 1	Black	*	8	Speed sensor 1	Black	*
9	Speed sensor 2	Yellow/Green	*	9	Speed sensor 2	Yellow/Green	*
10	Speed sensor 2	Brown		10	Speed sensor 2	Brown	
11	Stop sensor	Blue eller Brown		11	Stop sensor	Blue eller Brown	
12	Stop sensor	Blue eller Brown		12	Stop sensor	Blue eller Brown	
13	Motor 2	Stopmotor		13	Motor 2	Stopmotor	
14	Motor 2	Stopmotor		14	Motor 2	Stopmotor	
15	Pressure	Blue eller Brown		15	Pressure	Blue eller Brown	
16	Pressure	Blue eller Brown		16	Pressure	Blue eller Brown	
17	BIP - Motor 3	Brown	Sprinkler	17	BIP - Motor 3	Brown	Sprinkler
18	BIP + Motor 3	Blue	Sprinkler	18	BIP + Motor 3	Blue	Sprinkler
* If the distance counter count the wrong way, the speed sensor should be turned.				* If the distance counter count the wrong way, the cable on the terminal 8 and 9 must be interchange			

Program Rain 10	6 Pol Connector		
19 + GSM	Brown	+12 V	
20 - GSM	Blue (Green)		
21			
22			
23 + Pressure	Brown	12 V	
24 Pressure signal	White	0-5 V	

Technical data

Dimension (h*w*d)	170*140*100 [mm]
Voltage	10-15V DC
Current	6 mA (Rest) 30 mA (with GSM) 80 mA (with light) 5A motor max. current
Fuse	5A Fixed

Troubleshooting:

?

The turbine does not start when the **START** key is pressed.

Answer:

The magnet at the stop sensor is not in position or the sensor or sensor cable is damaged.

Stop sensor: The mark ■ must be on when the magnet is in position and off when the magnet is removed. See Menu 3.

A damaged cable can be assembled in an epoxy moulded assembly or with shrinkable tubing and glue.

However, since the sensors are more sensitive than telephone cables in the ground, cable assembly must be seen as an emergency solution.

If a pressostat is installed, the water must be pressurized. The mark ■ must be on when there is pressure.

?

No numbers in the display.

Answer:

Battery disconnected. Fuse inside the box may have blown. The fuse will blow if the battery is wrongly connected.

An additional fuse is available from the factory on a single fuse terminal on the circuit board.

Fuse 5A. Battery voltage 12V. See Menu 2.

?

Clock is set to 00:00

Answer:

If the power is interrupted, the clock is reset. The end time is then the number of hours and minutes until irrigation is complete.

See page 15 for setting the clock.

?

The number of metres is not counted correctly and the speed is not correct.

Answer:

If the speed is measured with a roller running on the hose, check whether the roller is running smoothly or if it is not installed properly on the hose. You will also need to check that the roller sensor with cable is functioning properly. See Menu 3 Speed sensor.

The 2 marks ■ ■ must light up in the following order from the right during unwinding: The first one turns on, then the second one turns on, the first one turns off, then the second one turns off. During rewind, this happens in reverse order.

?

Only half or perhaps 2/3 of the actual length has been counted.

Answer:

The stop bracket with magnet for the stop sensor may have jumped, so the magnet has been removed temporarily from the stop sensor.

This will reset the counter. Or a hose turn has been so loose that it has impacted the miswinding bracket.

This is usually the same as the impact on the stop bracket and has the same result.

Even if the metres are not saved in the memory, irrigation will still continue at the selected speed and the machine will stop as normal. However, there will be deviations if the speed is measured on a gear disc and the calculation is based on formulas entered in MACHINE DATA.

This is because the electronics do not know which hose layer the machine is running on. Finally, the metres can be entered manually.

Combining the various constants:

The machine will always be able to run with the factory-set constants. However, there will be different conditions from farm to farm and from machine to machine. Many requests can be met by changing the constants.

- 1. Slow start-up of turbine. Set machine data no. 13 initially to approx. 2-4.**

This causes the speed regulator valve to close only about halfway, after which continued closing is performed in steps until the rewind speed reaches the set speed. The valve can then be fine-tuned to close first to the point where the turbine starts running and then to close in steps until the set speed is achieved.
- 2. Slow opening of inlet. Set machine data no. 17 to 1.**

Opening for the water is then performed in steps.
- 3. Only one motor for speed regulation. Set machine data no. 12 to 0.**

Post-irrigation starts once the turbine stops, when the magnet at the stop sensor is affected. After the post-irrigation time has elapsed, the machine will restart and move to the mechanical stop.
- 4. Start up no. 2 machine when no. 1 stops. Set machine data no. 12 to 0.**

With a pressostat installed on both machines, set the pressostats between the machine's operating pressure and the pump pressostat's stop pressure. For example, the operating pressure may be 6 bar and the pump stop 9 bar. Set the pressostats on the machines to 7.5 bar. No. 2 machine will then start up when the slow closing of the first machine reaches the point where the pressure in the ground line reaches 7.5 bar. Be aware that if the height difference of the fields is too great, the required pressure differentials that the pressostat must be set to may be too great.
- 5. The machine should stop due to low pressure and with a pressostat installed. Set constant no. 6 to 1 and set machine data no. 12 to 2.**

This means that the stop valve opens instead of closing if the line connection to the stop valve is the same. After 2 minutes, close it again, otherwise you will not be able to obtain pressure at start-up. When machine data 12 is set to 2, the valve can only be opened with the stop sensor, stop button and monitoring. But not when the pressostat is switched off.

GSM-2G

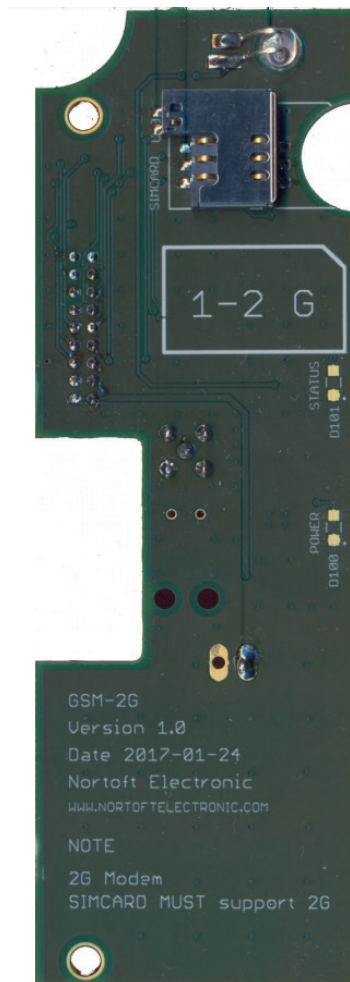

Functions	Modem
<p>Easy installation on PR10-12</p> <p>Low power consumption Total 10 mA consumption, PR10-12 and GSM-2G</p> <p>Visible status LED</p> <p>Supplied with Antenna with 2 metre cable Mounting accessories</p>	<ul style="list-style-type: none"> • Dual band 850/900/1800/1900 MHz • GPRS multi slot class 12/10 • GPRS mobile station class B • Compliant to GSM phase 2/2+ - Class 4 (2 W @850/900 MHz) - Class 1 (1 W @1800/1900MHz) • Temperature range: -40 °C ~ 85 °C

GSM

GSM-2G is a GSM modem made for PR10-12.

The machine can be started, stopped or queried about status by sending an SMS.

Commands

- Start** Starts the machine.
- Stop** Stops the machine
- Speed ##** Set the desired speed 3 to 400 m/h
- Status** Returns the current machine status.

SMS can be written in small, large or mixed characters.

If you call the modem from a GSM phone, you will receive an SMS with **Status**

Status

SPEED	30.0m/H
DOSE	22 mm
TIME 14:10	STOP 18:16
STATUS IRRIGATING	
DISTANCE	123m
BATTERY	12.8V
CHARGE ON	0.231A

SMS, sent from machine contains miscellaneous information.

SMS is sent at:

- LOW PRESSURE** The machine has stopped due to a lack of water pressure.
- STOP SENSOR:** The machine has reached the end and is ready for a new lane.
- STOP TELE:** Machine is stopped via an **SMS**
- STOP DIST:** The machine has reached the stopping distance. (Constant 8)
- STOP MONITOR:** Monitoring has stopped the machine. The machine has not moved for xx minutes. (See constant for monitoring)..

How to start the system:

Disconnect the battery from the electronics.

Insert the SIM card in a regular mobile phone and change the pin code to 1111.
 Try sending and receiving an SMS to see whether the SIM and account work as intended.

Note that SIM card MUST support 2G. Some operators do not support 2G.

Install the modem using the supplied threaded rods.

Insert the SIM card in the modem device.

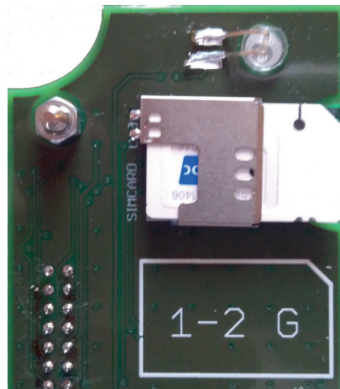

Connect the battery and set machine data #30

- = 0 No GSM
- = 1 Use GSM, all tele numbers can be used, no speed setting
- = 2 Use GSM, only the numbers created in the SMS list can be used.

SPEED	11.1m/h
DOSE	22 mm
TIME 14:10	Stop 7:43
M.DATA 30	1

See chapter for setting up data.

After approx. 30-45 seconds, the modem should be connected to the GSM network.

SIGNAL 23
NETWORK HOME
A: +45123456
B: +45234567

Signal strength, 0 - 31 and the network is then displayed in menu #6
 Signal strength of 10 or above is a stable connection.
 Signal strength of 99 indicates no signal.
 -Missing antenna
 -Very poor signal

Modem has LED to indicate status.

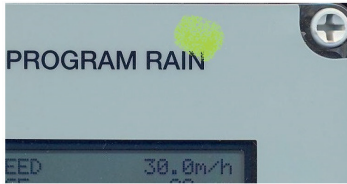

Green

Switched off

- Searching the network
- No SIM card in modem
- Incorrect PIN code
- No GSM network available

LED

Off

Flashes quickly

STANDBY
(registered on network)

Flashes slowly

Connection(TALKING)

On

When an SMS is received, the display shows:



Receiving an SMS, sender's phone number and 40 characters of message. All SMS can be received, but only known commands are accepted.

When an SMS is sent, the display shows:

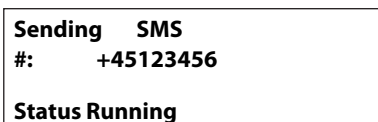

Sending an SMS, receiver's phone number and machine status.

Guarantee and complaints

For all products manufactured by Fasterholt Maskinfabrik A/S, Fasterholt Maskinfabrik A/S provides a guarantee for 24 months from the delivery date as regards errors in the processing and materials that are not due to ordinary wear and tear. The guarantee only applies provided that the product has been correctly installed, that only original spare parts have been used, and that such use is in accordance with Fasterholt Maskinfabrik's instructions and generally known practice.

As regards third-party goods that are part of the delivery, e.g. electronic equipment etc., the same guarantee is provided as the one provided to Fasterholt Maskinfabrik A/S by the sub-supplier.

If any errors are demonstrated in our products during the guarantee period, Fasterholt Maskinfabrik A/S will make cost-free repairs and renewals to the required extent as soon as possible within normal working hours.

If the goods for which a complaint has been made are to be replaced by new goods, such goods are sent including a new invoice. The goods for which a complaint has been made, incl. documentation about what is wrong and which machine number it is about, must be returned to Fasterholt Maskinfabrik A/S at the latest 14 days after the complaint was made for the purpose of crediting.

Only when we have received all necessary material will a warranty case be created. If the part is too large to send, Fasterholt Maskinfabrik must be contacted for another agreement. Photographic documentation will always be required in this context.

Fasterholt Maskinfabrik A/S is not liable for operating losses, loss of time, loss of profits or similar.

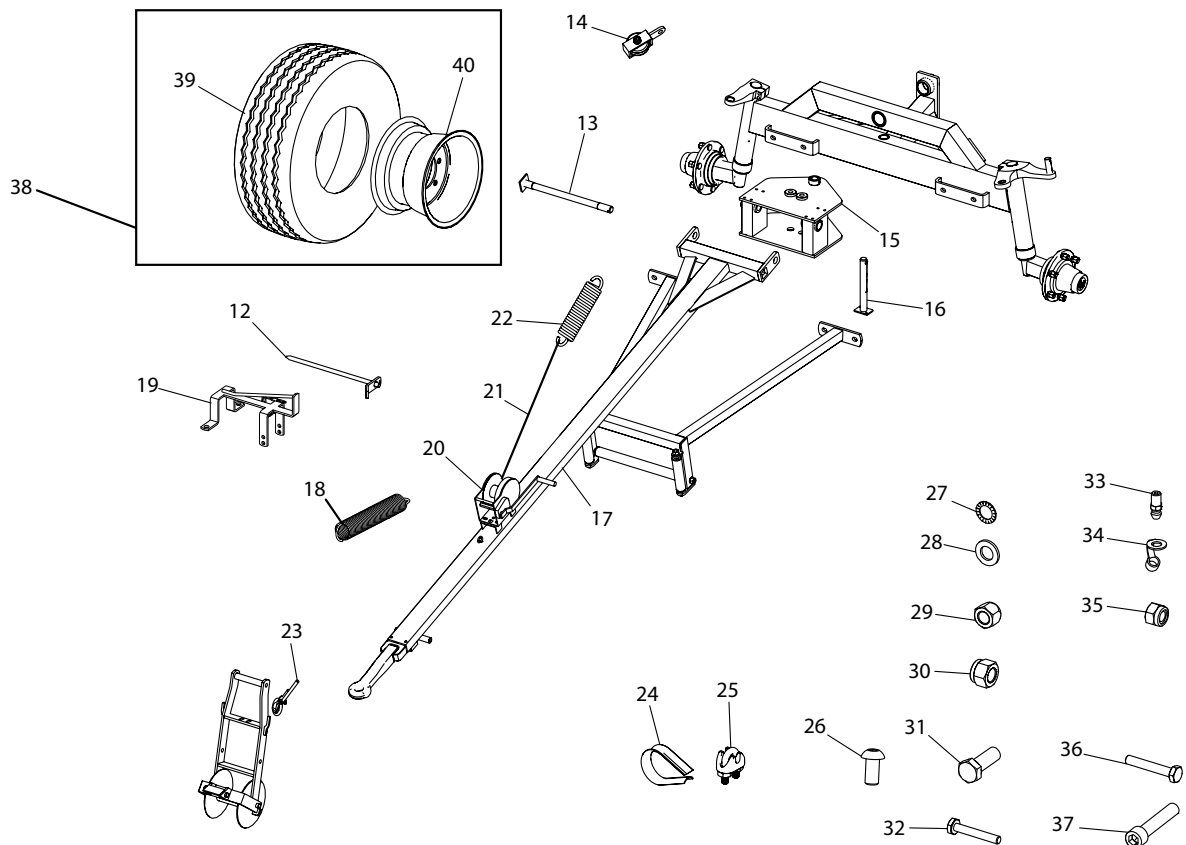
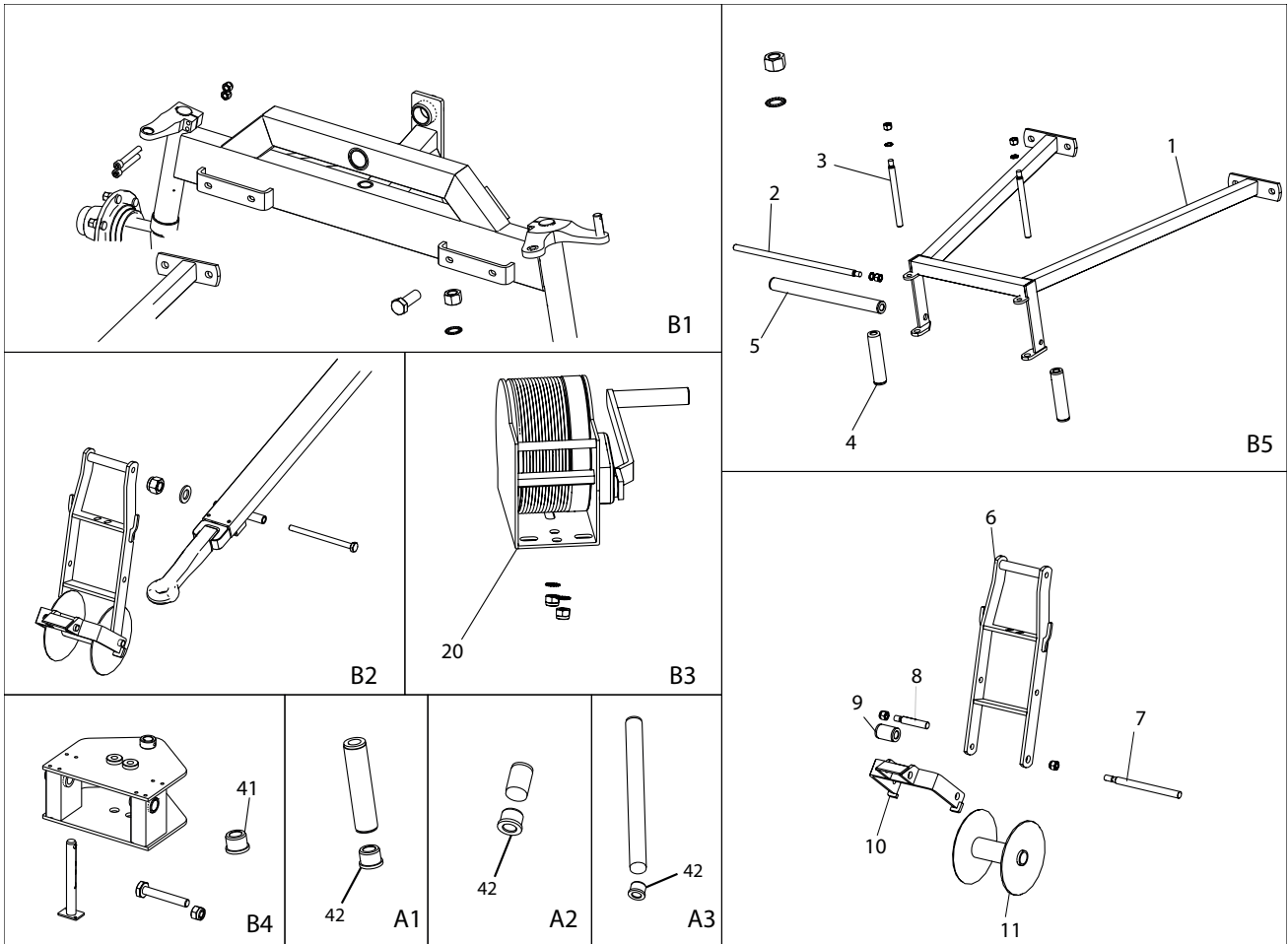

Item No.	Part No.	Qty	Description	Comments
1	1010107	1	Front hose guide	
2	1761026	1	Shaft	
3	761025	2	Shaft	
4	761023	2	Support roller 5/4 170 mm	A1
5	1761024	1	Support roller 5/4	A3
6	1008210	1	Bracket for steering wheel	
7	1008218	1	Shaft	
8	761273	1	Shaft 115 mm	
8	2001255	1	Shaft 185 mm	
9	761272	1	Support roller 5/4 50 mm	A2
9	2001254	1	Support roller 5/4 120 mm	
10	1008215	1	Safety stop	Discontinued use 2013562
10	2013562	1	Safety stop 110 mm	Remember 2001255 & 2001254
11	1008205	1	Steering wheel	
12	1001255	2	Ground spike	
13	1008222	1	Horizontal split pin	
14	761015-10	1	Cable roller	
15	1009170	1	Drawbar bracket	
16	1008220	1	Vertical split pin	
17	1008200	1	Drawbar	
18	2003929	1	Spring	
19	1761006	1	Wheel chock	
20	505500	1	Winch	
20	762036	1	Complete winch with cable	

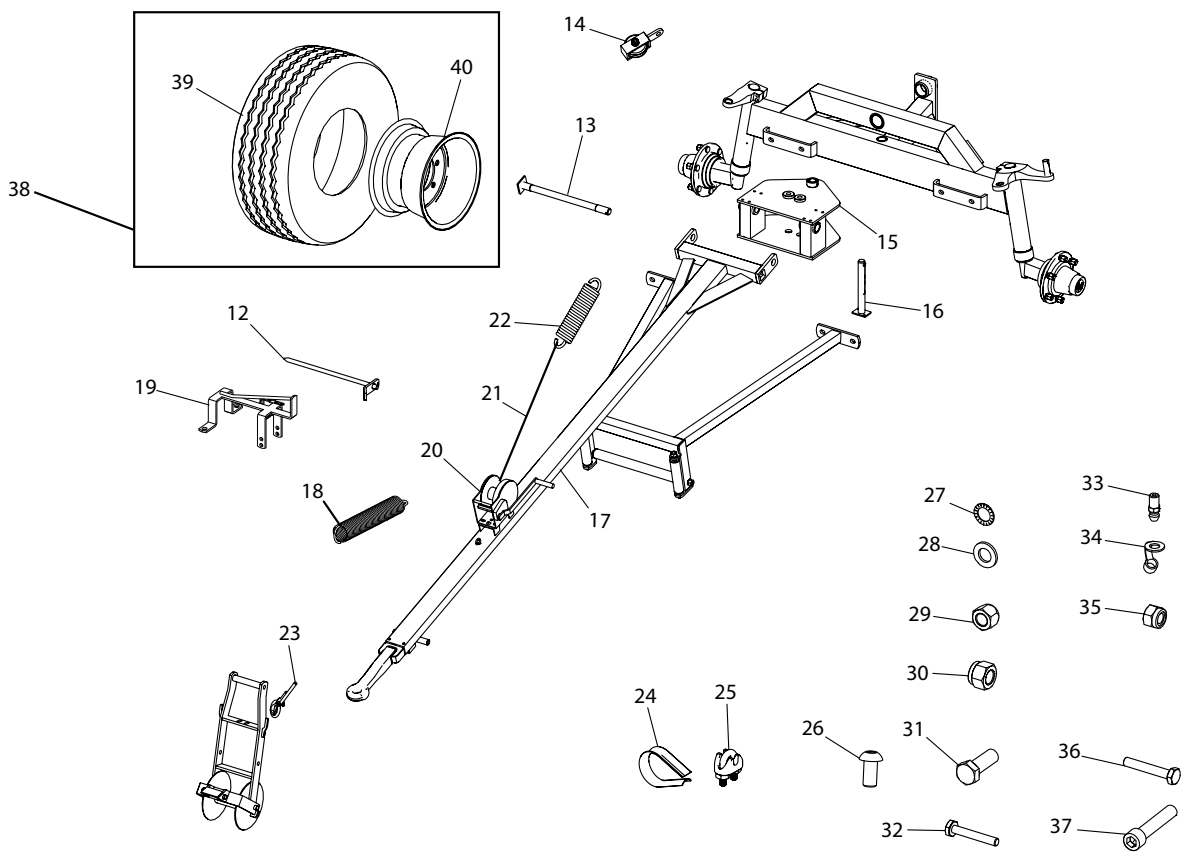
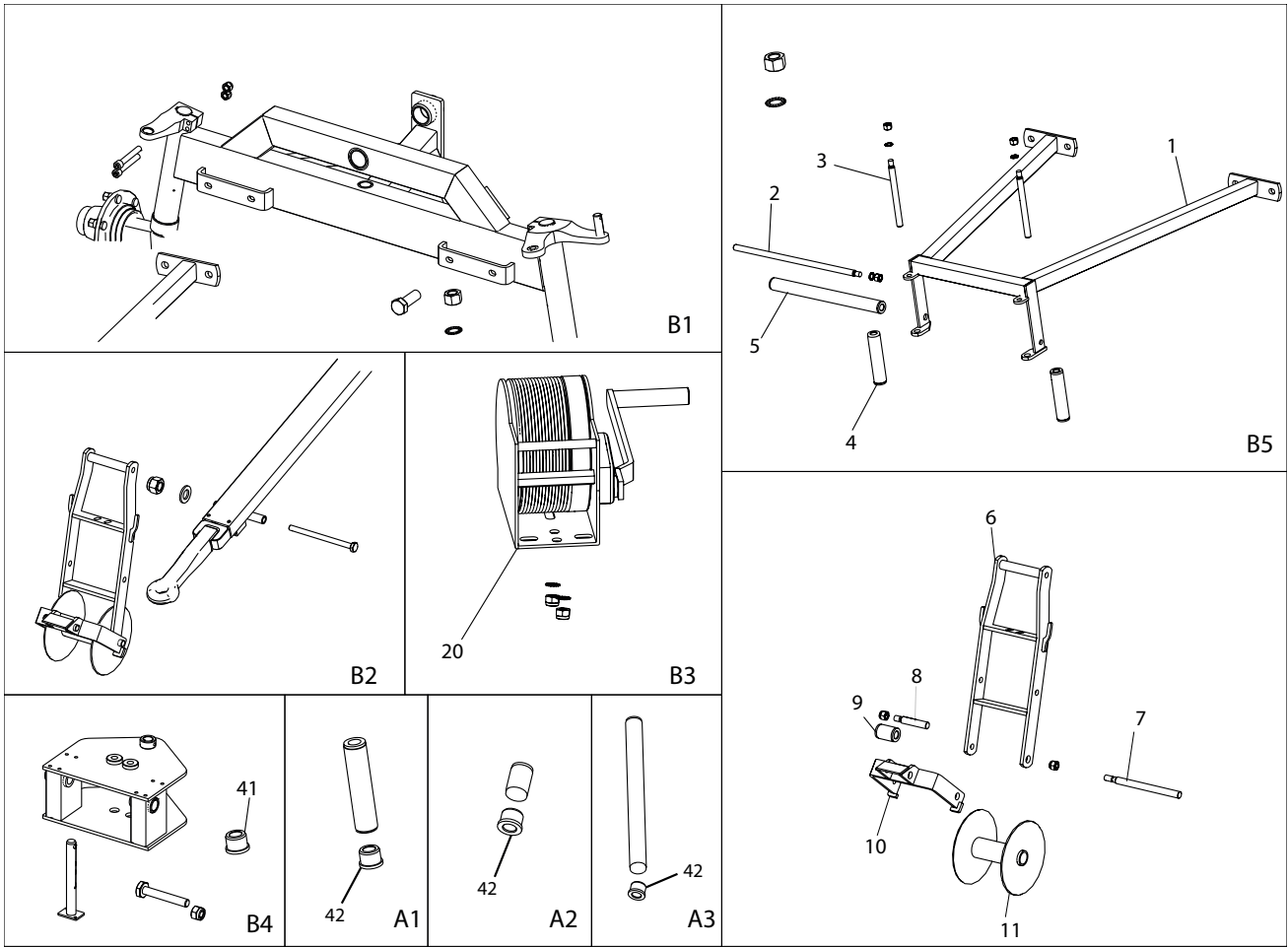

Item No.	Part No.	Qty	Description	Comments
21	1007803	1	Cable Ø5x3500 mm	
22	1008203	1	Spring	
23	1007812	1	Cable Ø5 x 7700 mm	
24	761012-1	1	Cable thimbles	
25	761013-1	3	Cable lock	
26	095010020	2	M10 x 20 Round head	B3
27	763916	8	M16 Riplock	B1 & B5 & B2
28	050316	4	M16 Plain washer	B1
29	040416	7	M16 Steel nut	B1 & B5 & B2
30	044012	4	M12 Lock nut	B1
31	022216045	4	M16 x 45 Steel bolt	B1
32	021010065	1	M10 x 65 Steel set bolt	B4
33	761286	1	Grease nipple	
34	761286-2	1	Lubrication nipple Cap	
35	044010	3	M10 Lock nut	B3
36	021016230	1	M16 x 230 Steel set bolt	B2
37	030512085	4	M12 x 85 Int. hex	B1
38	1008750	1	Comp Wheel	
39	1008752	2	Wheel	
40	1008756	2	Rims	
41	1008226	2	Collar bushing	
42	761271	6	Nylon bearing for Support roller	

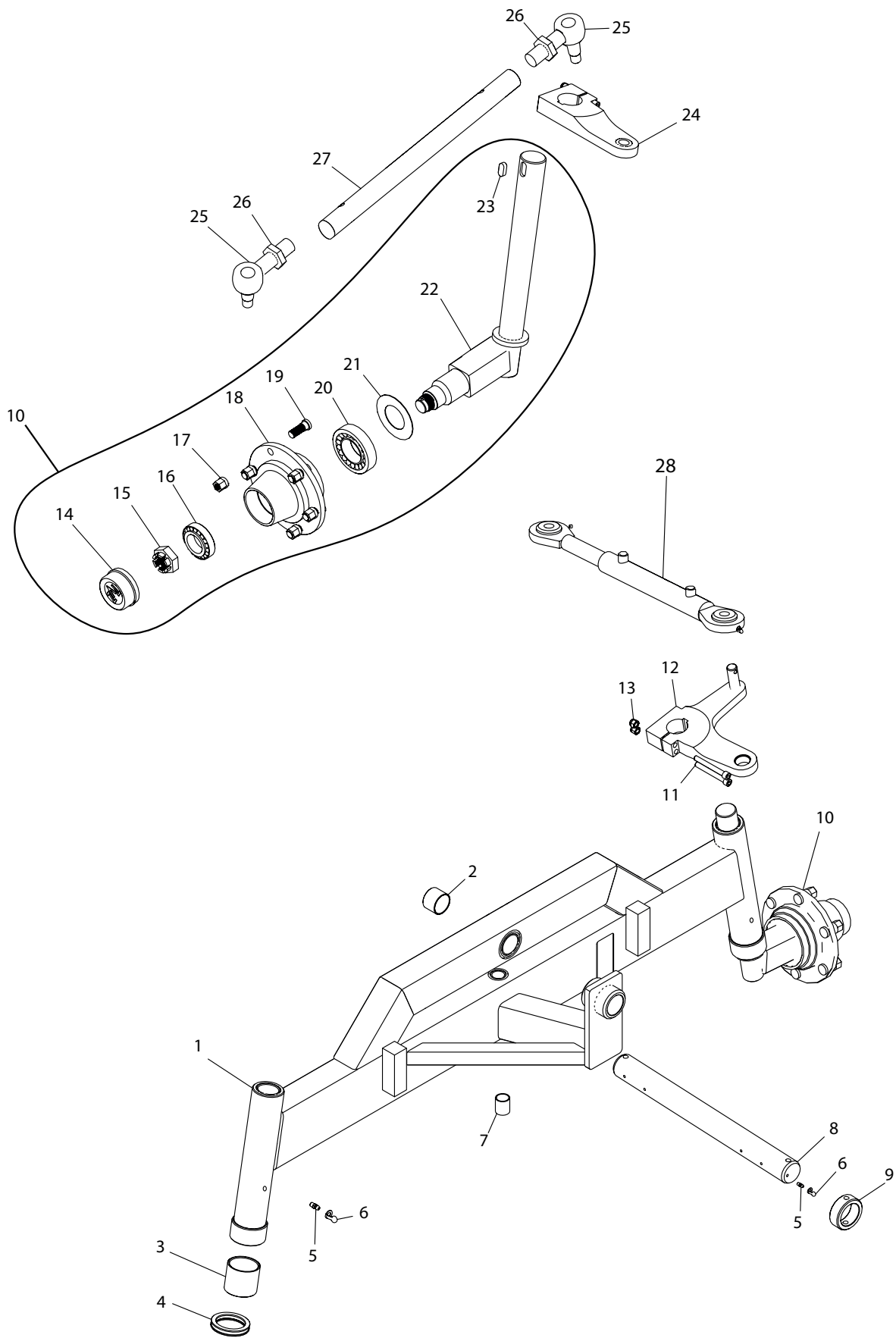

Item No.	Part No.	Qty	Description	Comments
1	1009175	1	Front axle	1810 mm
1	1009177	1	Front axle	2000 mm
2	1008101	3	Bushing	
3	1009186	4	Bushing for spindle	
4	1009187	2	Pressure bearing	
5	761286	3	Grease nipple	
6	761286-2	2	Cap for lubrication nipple	
7	1008102	1	Bushing	
8	1007629	1	Shaft for front axle	
9	1008195	1	Stop ring	
10	1009183	2	Spindle comp with Hub	
11	030012100	4	M12x100 Int. hex Unbraco	
12	1009191	1	Spindle arm	
13	044012	4	M12 Lock nut	
14	1009181-6	2	Hub cap	
15	1009181-5	2	Crown nut	
16	1009181-1	2	Tapered roller bearing	
17	1009181-4	12	Hub nut M18	
18	1009181	2	Hub	
19	1009181-3	12	Hub bolt M18	
20	1009181-2	2	Tapered roller bearing	
21	1009181-7	2	Sealing washer	
22	1009185	2	Spindle	
23	1009188	2	Feather key	
24	1009192	1	Spindle arm Right	
25	1008155	4	Tie rod end	
26	1008157	4	Counter nut	
27	1009196	2	Steering lever	1800 mm
27	1009197	2	Steering lever	2000 mm
28	1008585	2	Cylinder	

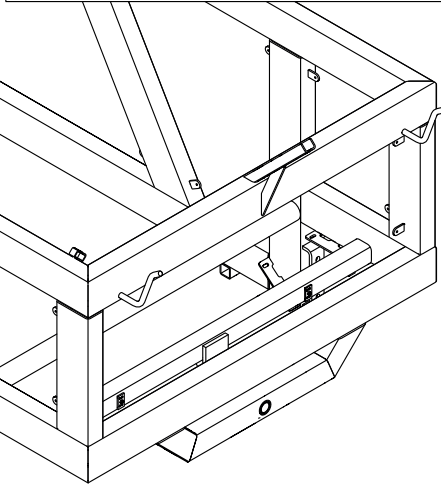
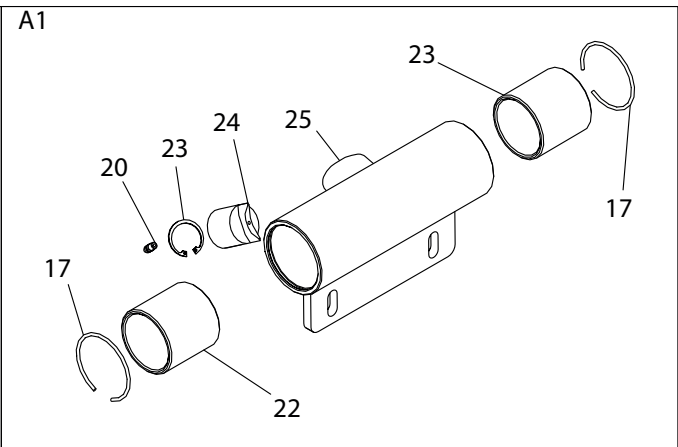
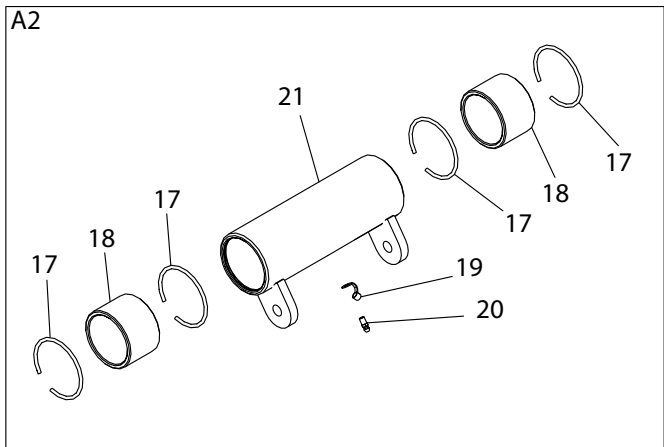

- 26 —
- 27 —
- 28 —
- 29 —
- 30 —
- 31 —

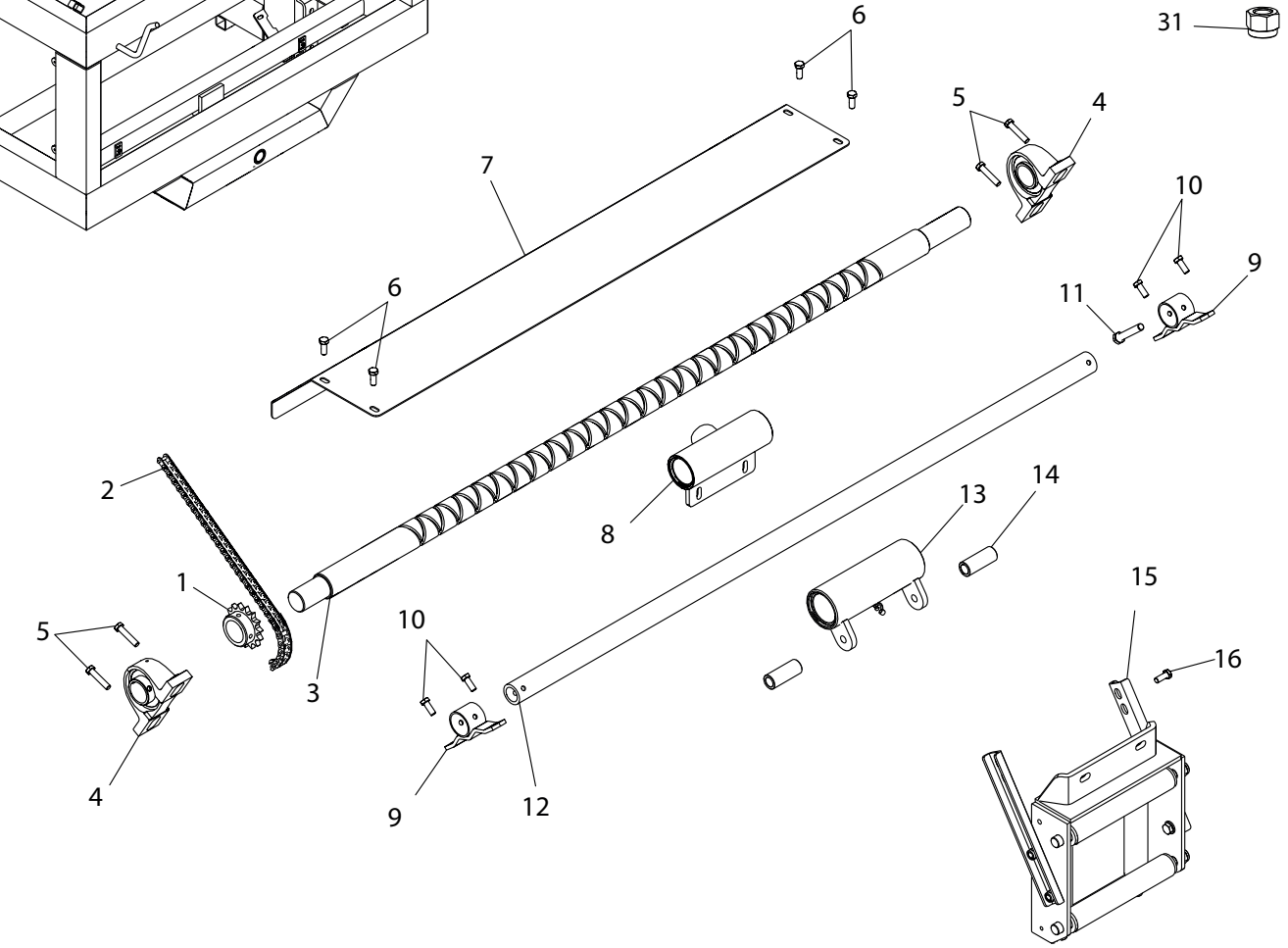

Item No.	Part No.	Qty	Description	Comments
1	1001290	1	Sprocket 3/4 18T	Ø100 Hose
1	761290	1	Sprocket 3/4 15T	Ø110 Hose
2	1008530	1	Chain for cross track	
3	1008460	1	Cross track shaft Ø100	
3	1008465	1	Cross track shaft Ø110	
4	761289-1	2	Bearing	
5	022216050	4	M16 x 50 Set bolt	
6	022212030	4	M12 x 30 Set bolt	
7	2351078	1	Guard over hose guide	
8	761282	1	Comp Guide sleeve	
9	1008485	2	Holder for support pipe	
10	022212030	4	M12 x 30 Set bolt	
11	021010075	2	M10 x 75 Steel bolt	
12	1008492	1	Support pipe for hose guide	
13	See A2	1		
14	1008207	2	Spacer bushing for inner hose guide	
15	See Page 40	1		
16	022212055	2	M12 x 55 Set bolt	
17	761329	4	Spring ring	
18	761293	4	Bushing	
19	761286-2	2	Cap for lubrication nipple	
20	761286	2	Grease nipple	
20	2008560	2	Grease nipple 1/4"	
21	1008475	1	Sleeve for support pipe carriage	
22	761293	2	Bushing	
23	761285	1	Retaining ring	
24	761283	1	Guide shaft (Pin)	
25	761282-1	1	Guide sleeve	
26	050316	4	M16 Plain washer	
27	763916	8	M16 Riplock	
28	763912	4	M12 Riplock	
29	044010	2	M10 Lock nut	
30	044012	8	M12 Lock nut	
31	044016	4	M16 Lock nut	

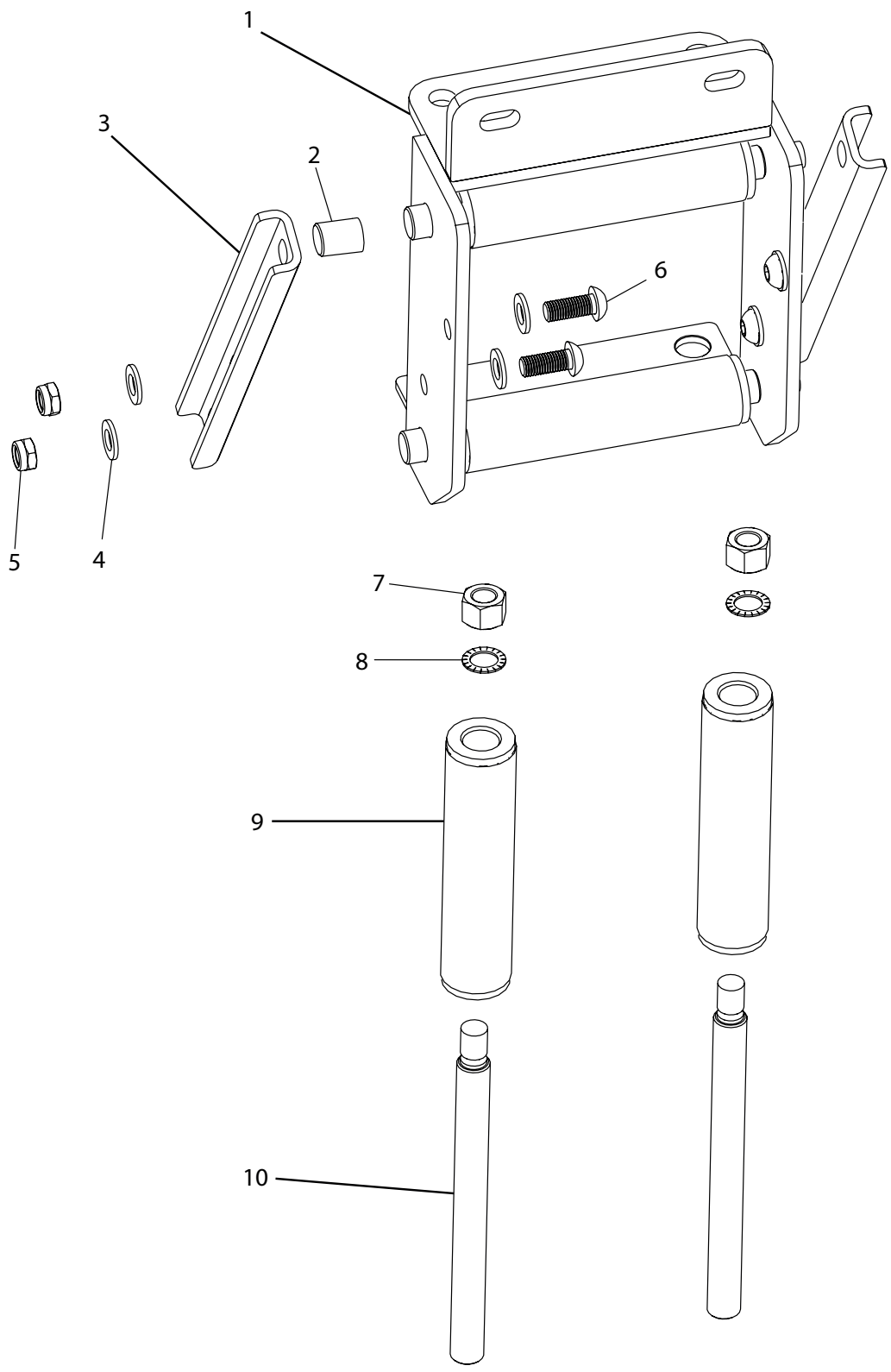

Item No.	Part No.	Qty	Description	Comments
1	1008480	1	Frame for carriage hose guides	
2	1008207	2	Bushing	
3	1008490	2	Brace for carriage	
4	763912	4	M12 Riplock	
5	044012	4	M12 Lock nut	
6	095012035	4	M12 x 35 Int. hex	
7	040416	4	M16 Steel nut	
8	763916	4	M16 Riplock	
9	761023	4	Support roller with bearings	
10	761025	4	Shaft	

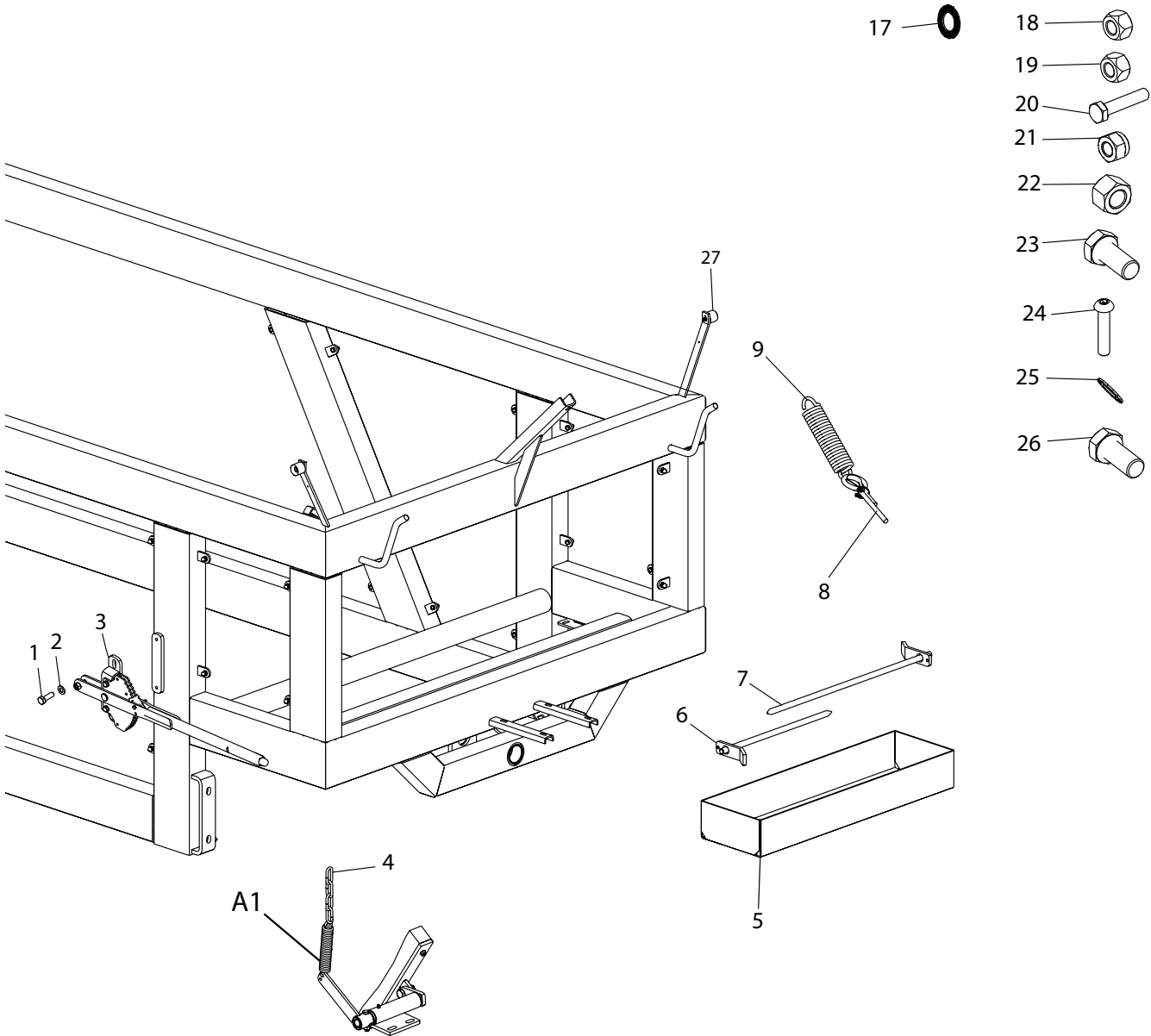
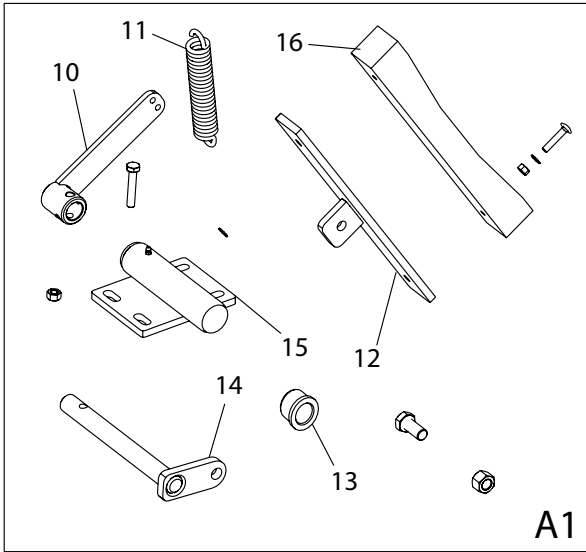
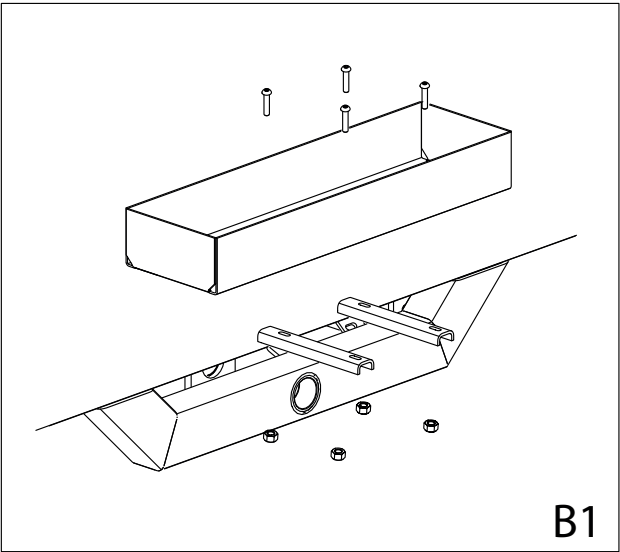

Item No.	Part No.	Qty	Description	Comments
1	022210030	2	M10 x 30 Set bolt	
2	050310	2	M10 Plain washer	
3	761113-2	1	Coupling lever	
4	1550041270	1	Chain 250 mm	
5	1009341	1	Toolbox	
6	1001255	1	Ground spike 50 cm	
7	1010115	1	Ground spike 73 cm	
8	1007803	1	Cable 3.5 m	
9	1008203	1	Spring	
10	1009275	1	Arm for brake	
11	761110	1	Spring	
12	902119	1	Brake shoe	
13	1009337	2	Bushing for brake shaft	
14	1008355	1	Shaft for brake	
15	1009335	1	Pipe for brake bushings	
16	902120	1	Brake block	
17	050306	4	M6 Plain washer	B1
18	040408	2	M8 steel nut	A1
19	044010	1	M10 Lock nut	A1
20	022208040	2	M8 x 40 Set bolt	A1
21	044016	1	M16 Lock nut	A1
22	044006	4	M6 Lock nut	B1
23	021010055	1	M10 x 55 Steel bolt	A1
24	035206020	4	M6 x 20 Carriage bolt	B1
25	763908	4	M8 Riplock	A1
26	022216035	1	M16 x 35 Set bolt	A1
27	1327102020	8	Door holder female	

Qty	Description	Comments
22	M6 x 12 Int. hex	
18	M6 Plain washer	
22	M6 Lock nut	
2	Door holder	
2	M6 x 25	

A1

Qty	Description	Comments
25	M6 x 12 Int. hex	
18	M6 Plain washer	
25	M6 Lock nut	
2	Door holder	
2	M6 x 25	

A3

Qty	Description	Comments
22	M6 x 12 Int. hex	
18	M6 Plain washer	
22	M6 Lock nut	
2	Door holder	
2	M6 x 25	

A2





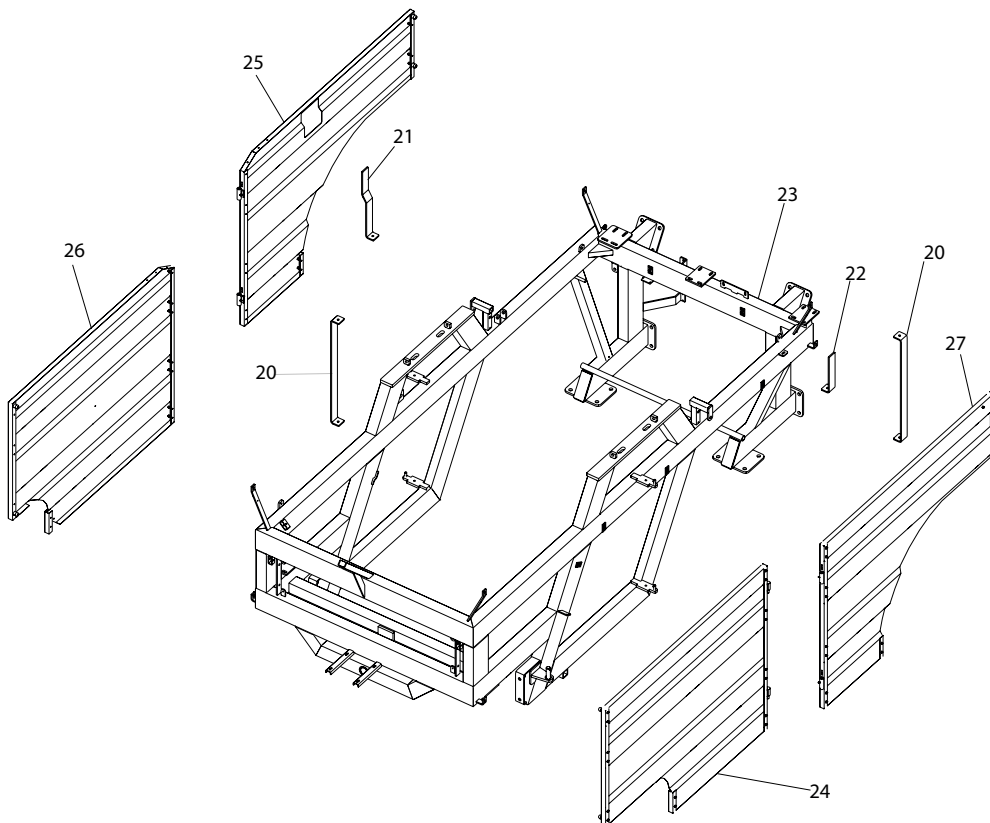
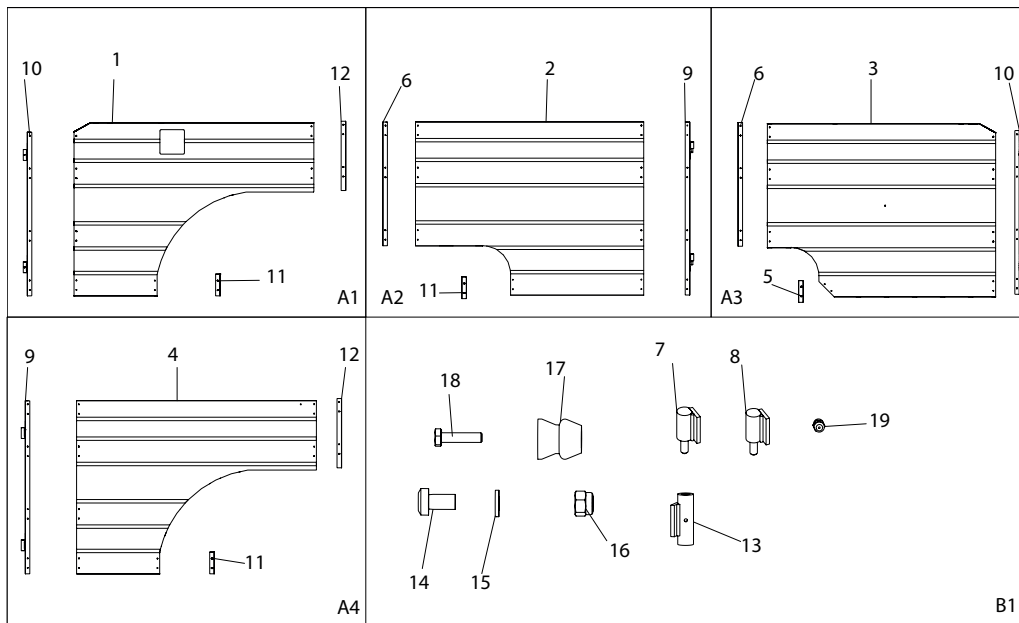

Qty	Description	Comments
20	M6 x 12 Int. hex	
18	M6 Plain washer	
20	M6 Lock nut	
2	Door holder	
2	M6 x 25	

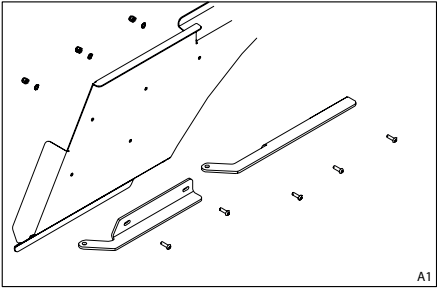
A4



Item No.	Part No.	Qty	Description	Comments
1	2003084	1	Side guard RB	
2	2003092	1	Side guard LF	
3	2002965	1	Side guard RF	
4	2003093	1	Side guard LB	
5	2003473	1	Edge profile	
6	2003118	2	Edge profile	
7	2003129-1	2	Left Hinge	
8	2003128-1	2	Right Hinge	
9	2003088	2	Edge profile	
10	2003386	2	Edge profile	
11	2003127-1	4	Hinge	
12	2003121	3	Edge profile	
13	2003119	2	Edge profile	
14	763726	89	M6 x 12 Int. hex	B1
15	050306	72	M6 Plain washer	B1
16	095906	89	M6 Lock nut	B1
17	1327102021	8	Door holder Male	B1
18	022206025	8	M6 x 25	B1
19	761286	2	Grease nipple	A1 & A4
20	2003290-1	2	Bracket for centre console	
21	2003243-1	1	Bracket for guard	
22	2003242-1	1	Bracket for protective guard	
23	2006219	1	Frame	
24	2003122	1	Guard L Front	A2
25	2003124	1	Guard R Back	A1
26	2003125	1	Guard R Front	A3
27	2003123	1	Guard L Back	A4



- 26 — 
- 27 — 
- 28 — 
- 29 — 
- 30 — 
- 31 — 

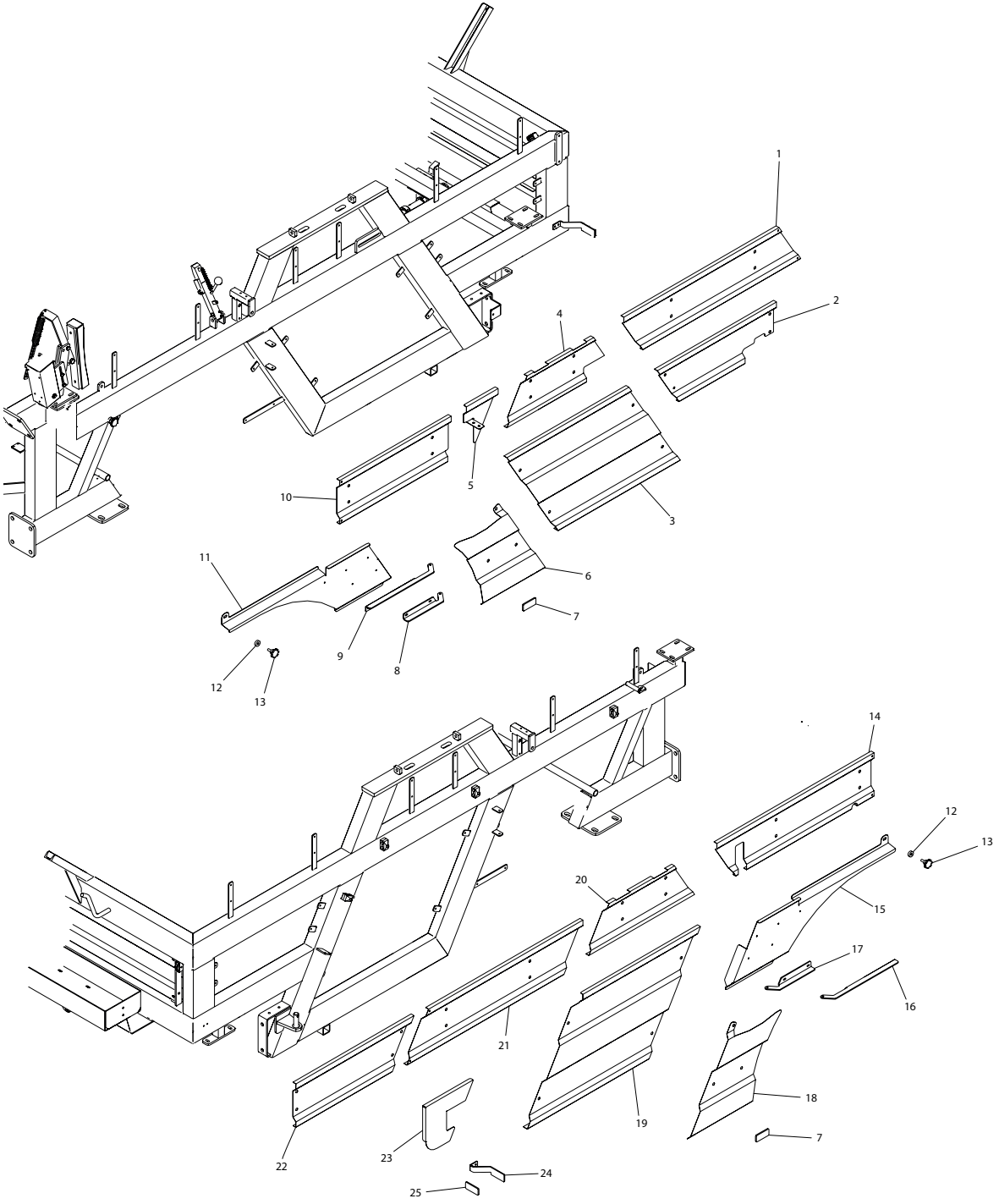

Item No.	Part No.	Qty	Description	Comments
1	2013721	1	Side guard right	
2	2013719	1	Side guard right	
3	2013718	1	Side guard right	
4	2013722	1	Side guard right	
5	2013811	1	Side guard right	
6	2013800	1	Side guard right	
7	2014846	2	Reflex	
8	2013796	1	Hinge for door right	
9	2013812	1	Hinge for door right	
10	2013810	1	Side guard right	
11	2013726	1	Side guard right	
12	2014104	2	Disc for guard	
13	2014120	2	Star grip	
14	2013827	1	Side guard left	
15	2013833	1	Side guard left	
16	2013841	1	Hinge for door left	
17	2013836	1	Hinge for door left	
18	2013842	1	Side guard left	
19	2013716	1	Side guard left	
20	2013723	1	Side guard left	
21	2013720	1	Side guard left	
22	2013717	1	Side guard left	
23	2013950	1	Side guard left	
24	2014399	2	Reflex holder	
25	2014348	2	Reflex	
26	095006020-1	10	M6 x 20 internal hexagon	
27	763906	10	M6 riplock	
28	044006	10	M6 lock nut	
29	022208020	48	M8 x 20 set bolt	
30	050208	48	M8 washer	
31	763930	48	M8 eyebolt	

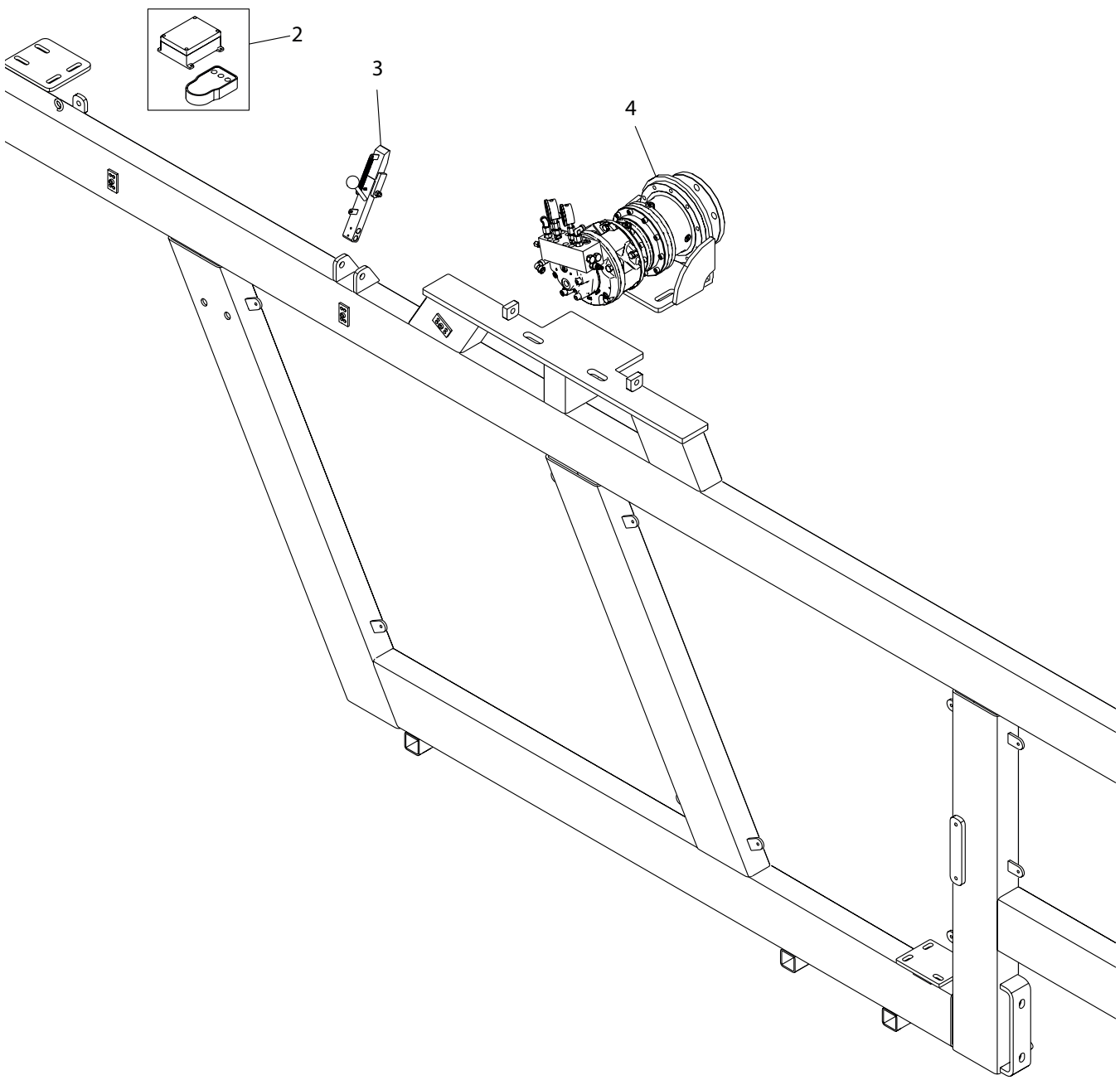
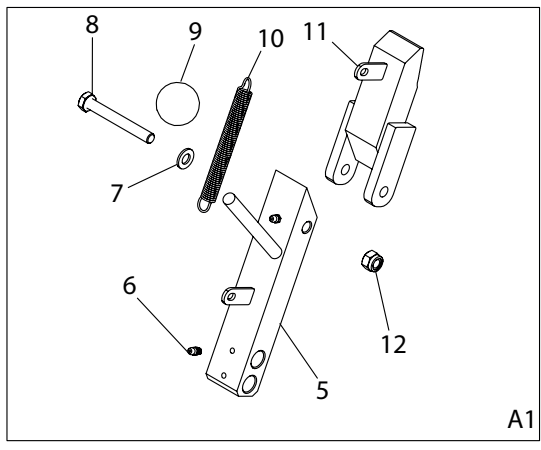
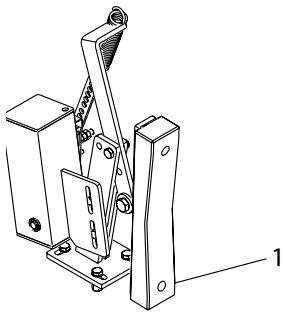

Item No.	Part No.	Qty	Description	Comments
1	E1091	1	Electric brake	
2	-	-	-	-
3	1008260	1	Locking pawl	
4	1013900	1	Drive set	
5	1008260-10	1	Loose part for locking pawl	
6	761286	1	Grease nipple	
7	050310	1	M10 Plain washer	
8	022210080	1	M10 x 80 Set bolt	
9	763300	1	Ball lever	
10	570114	1	Spring	
11	1008260-11	1	Lock for locking pawl	
12	044010	1	M10 Lock nut	

Pos no. 2 (Remote control for electric brake)

Item No.	Part No.	Qty	Description	Comments
1	762043	1	Receiver for remote control	
2	762042	1	Handheld transmitter	
3	762041	1	Receiver + Handheld transmitter Set	

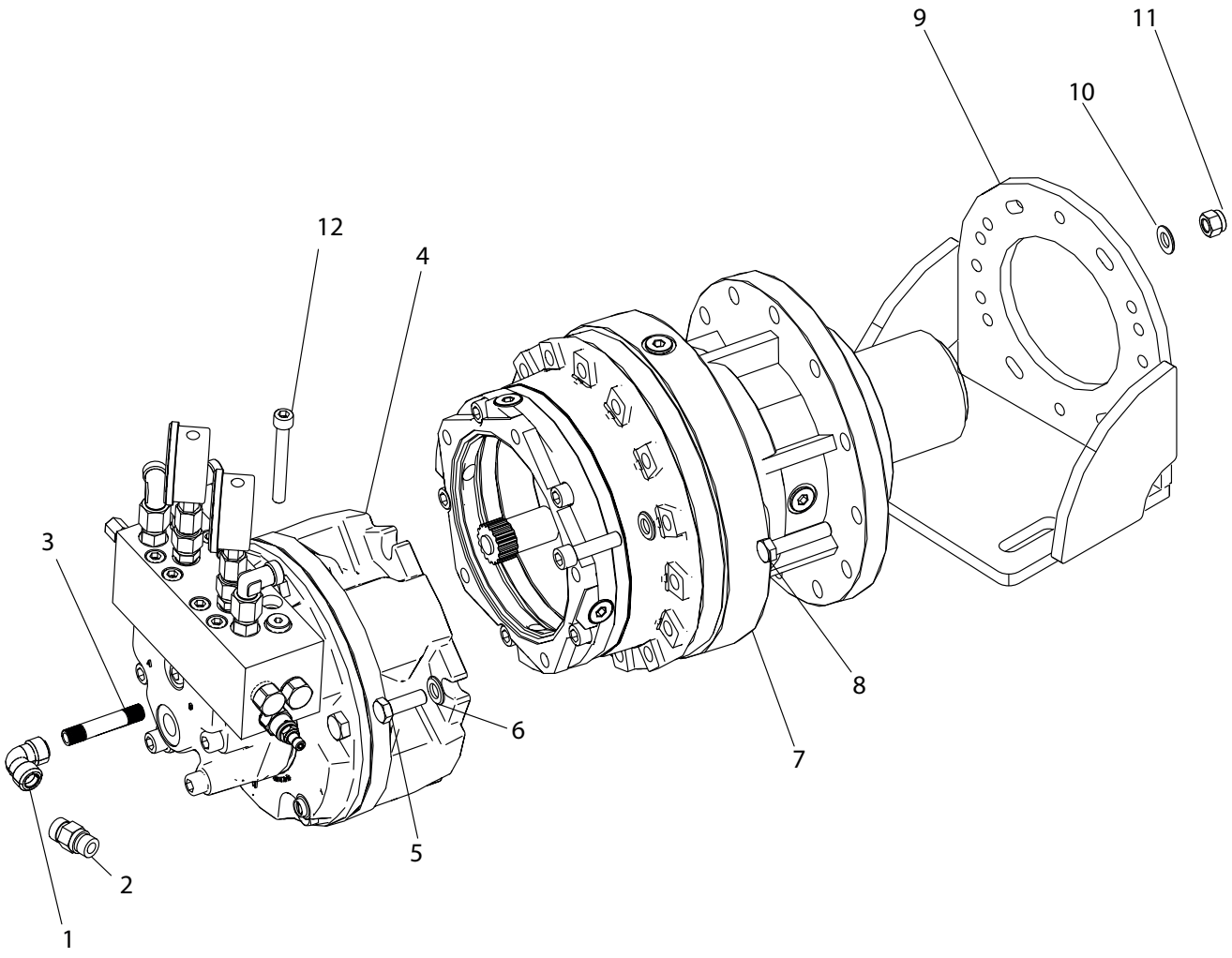

Item No.	Part No.	Qty	Description	Comments
1	000090402	1	Angle 1/4	
2	1010978	1	Nipple	
3	012120402	1	Nipple pipe 1/4	
4	1013930	1	Piston motor	
5	030512130	5	M12 x 130 int. hex	
6	056212	5	Spring washer	
7	1013910	1	Gear for piston motor	
8	021012050	10	M12 x 50 Steel bolt	
9	1010700	1	Bracket for hose drum drive	
10	763912	20	M12 Riplock	
11	040412	10	M12 Steel nut	
12	030010080	8	M10 x 80 round with int. hex	

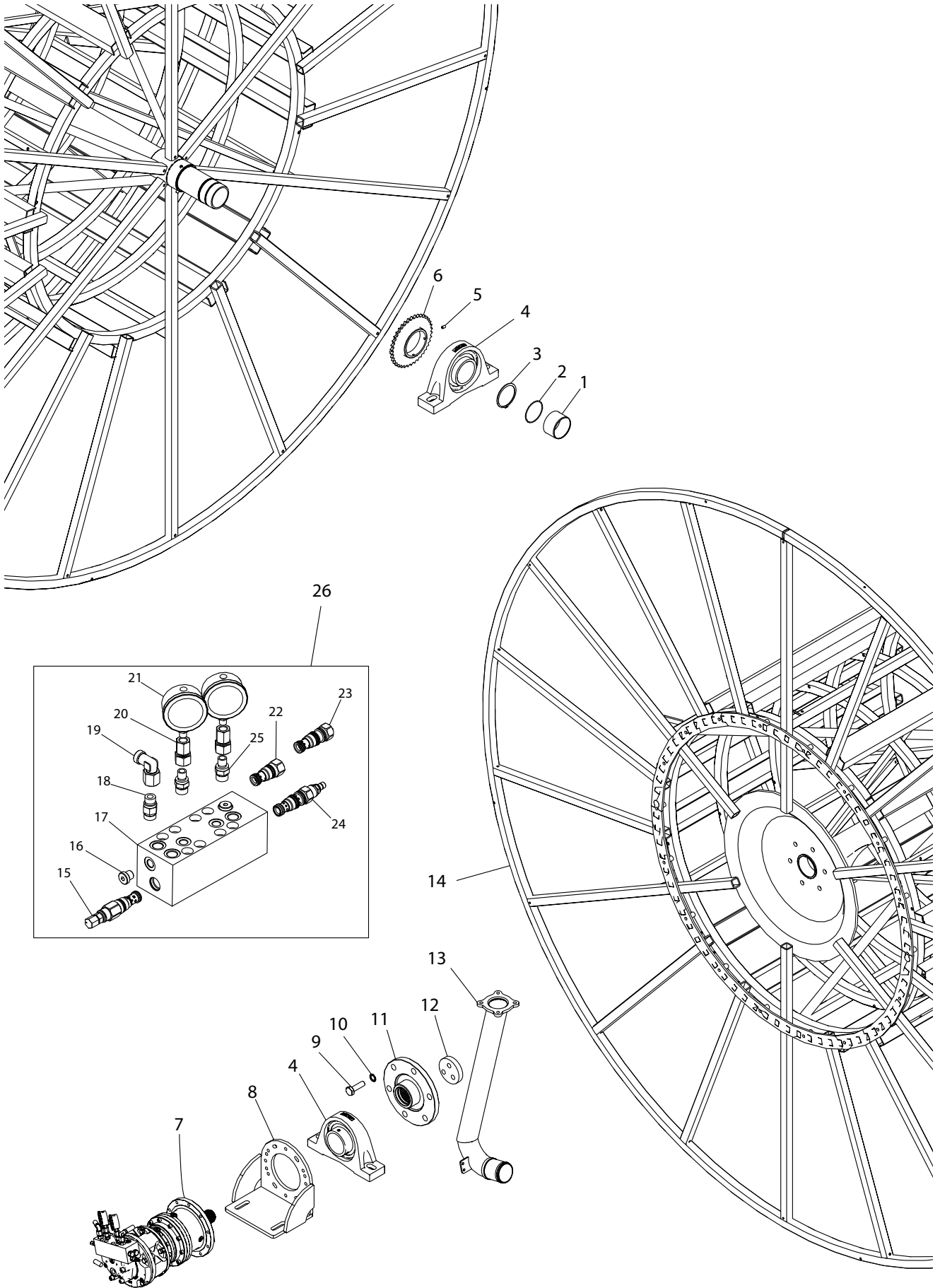

Item No.	Part No.	Qty	Description	Comments
1	1001270	1	Stainless bushing	
2	624099	1	O-ring for stainless bushing	
3	1007930	1	Retaining ring ext. Ø100	
4	1001098	1	Bearing	
5	033010016	2	M10x16 Stop screw	
6	1008065	1	Sprocket	
7	1013900	1	Drive set	Reggiana
8	1010700	1	Bracket for hose drum drive	
9	023020070-1	6	M20x70 Set bolt.	
10	763615	6	M20 Plain washer	
11	2001477	1	Flange for drive	
12	2003382	1	Lock washer	
13	2003334	1	Inlet pipe for hose drum Ø100	
13	2003355	1	Inlet pipe for hose drum Ø110	
14	1008055	1	Hose drum FM4550H	
15	1013965	1	Back pressure valve 5 bar	
16	1010972	1	Plug	
17	1013940	1	Alu block	
18	1007724	3	Nipple	
19	1008622	3	Angle	
20	1010979	1	Nipple for manometer	
21	761163-4	1	Manometer 0-100 bar	
21	1001163	1	Manometer 0-10 bar	
22	1013943	1	Pilot controlled check valve	
22	1010966	1	Pilot shut-off/check valve	
23	1013948	1	Check valve for drum roller	
24	1013942	1	3-way pressure reduction valve	
25	1010978	2	Nipple	
26	1013940-1	1	Exchanger Alu block on drum roller	

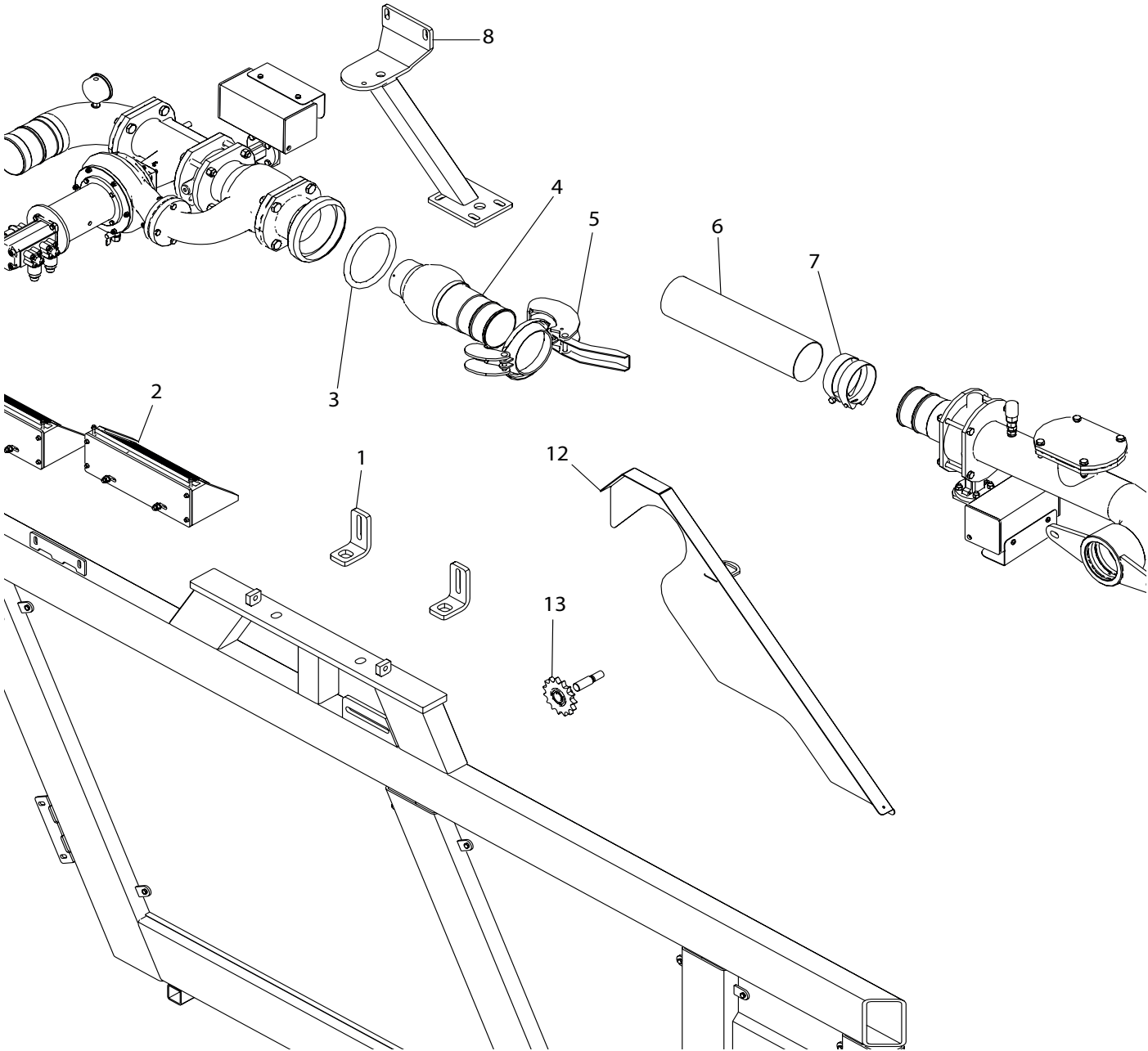
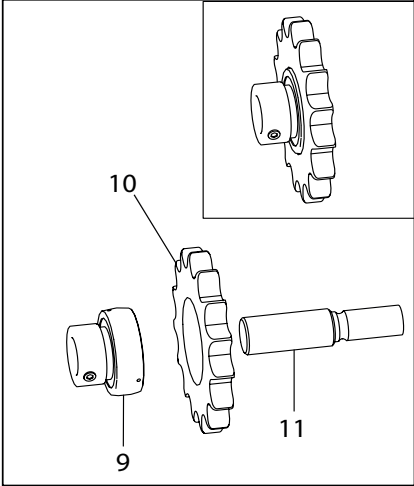
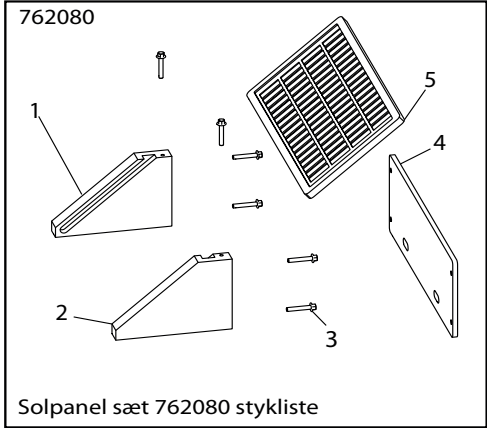

Item No.	Part No.	Qty	Description	Comments
1	2001491	2	Angle bracket	
2	762080	2	Solar panel set	
3	14050043	1	Rubber ring HK 108	
4	1009290	1	HK 108 Ball	
5	14050013	1	HK 108 Locking ring	
6	16050210	1	Soft hose no. per running metre	930 mm
7	16200726	4	Hose clamp	
8	1009120	1	Suspension for turbine	
9	761276	1	Bearing	
10	311215	1	Sprocket	
11	761275	1	Shaft	
12	1007695	1	Chain guard	
13	2351278	1	Sprocket comp	

Parts list 762080 Solar panel

Item No.	Part No.	Qty	Description	Comments
1	2001259	1	Holder for solar cell L	
2	2001260	1	Holder for solar cell R	
3	510555	1	Ø4.8 x 32 SuperTEKS 6	
4	2002533	1	Galvanized plate for solar panel	
5	1005523	1	Solar panel for constant	

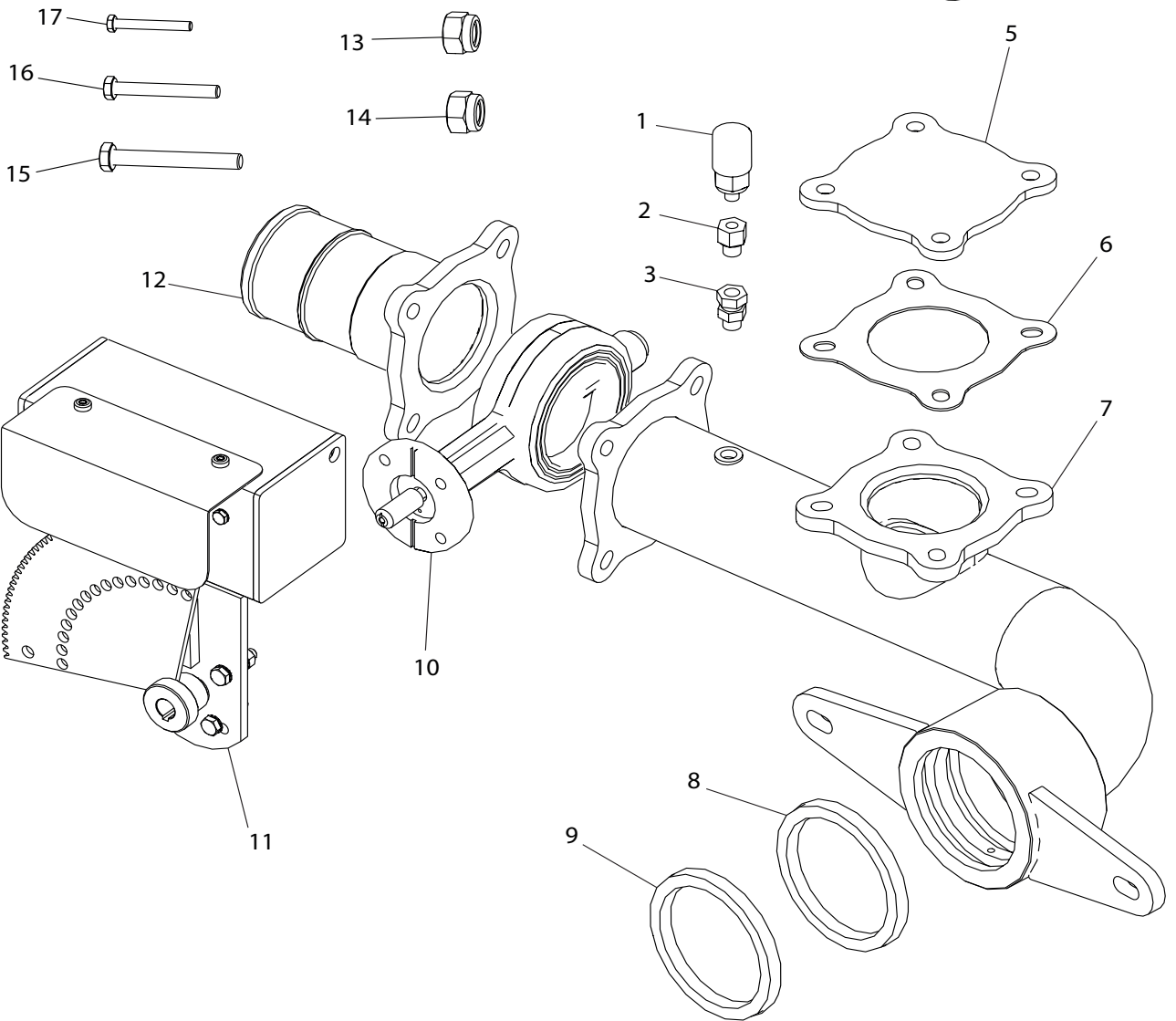
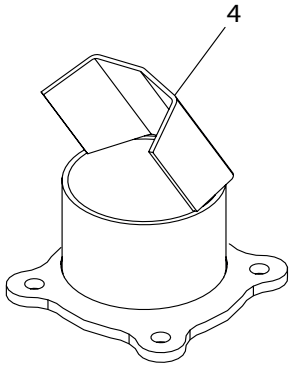
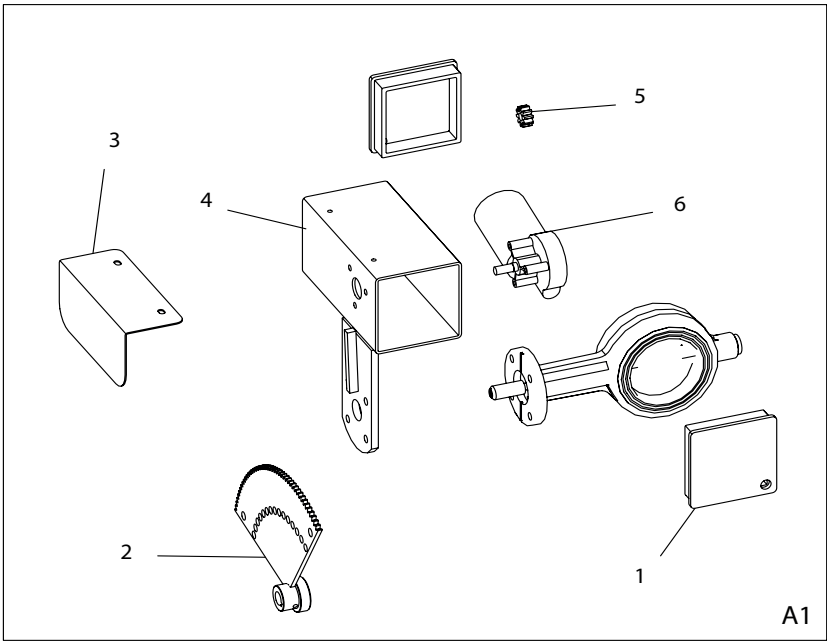

Item No.	Part No.	Qty	Description	Comments
1	1007545	1	Pressostat	
2	1013834	1	Nipple sleeve 1/4x1/8	
3	1013819	1	Nipple with union nut 1/4x1/4	
4	1007030	1	Spreader for low pressure	
5	1007098	1	Blind flange	
6	631112	1	Gasket	
7	1009295	1	Head with pipe and flange	
8	1102138	1	Sealing ring	
9	1001095	1	Sealing ring	
10	1007250	1	Butterfly valve	
11	1007230	1	Complete motor valve	
12	1009312	1	Flange with hose connector	
13	044008	4	M8 Lock nut	
14	044010	8	M10 Lock nut	
15	021010085	4	M10 x 85 Steel bolt	
16	022210040	4	M10 x 40 Steel set bolt	
17	021008035	4	M8 x 35 Steel bolt	

Parts list No. 11

Item No.	Part No.	Qty	Description	Comments
1	1007175	2	End plug	A1
2	1007195	1	Gear for valve	A1
3	1007185	1	Guard for motor valve	A1
4	1007171	1	Motor housing	A1
5	1007190	1	Gear for motor	A1
6	1007180	1	Motor	A1

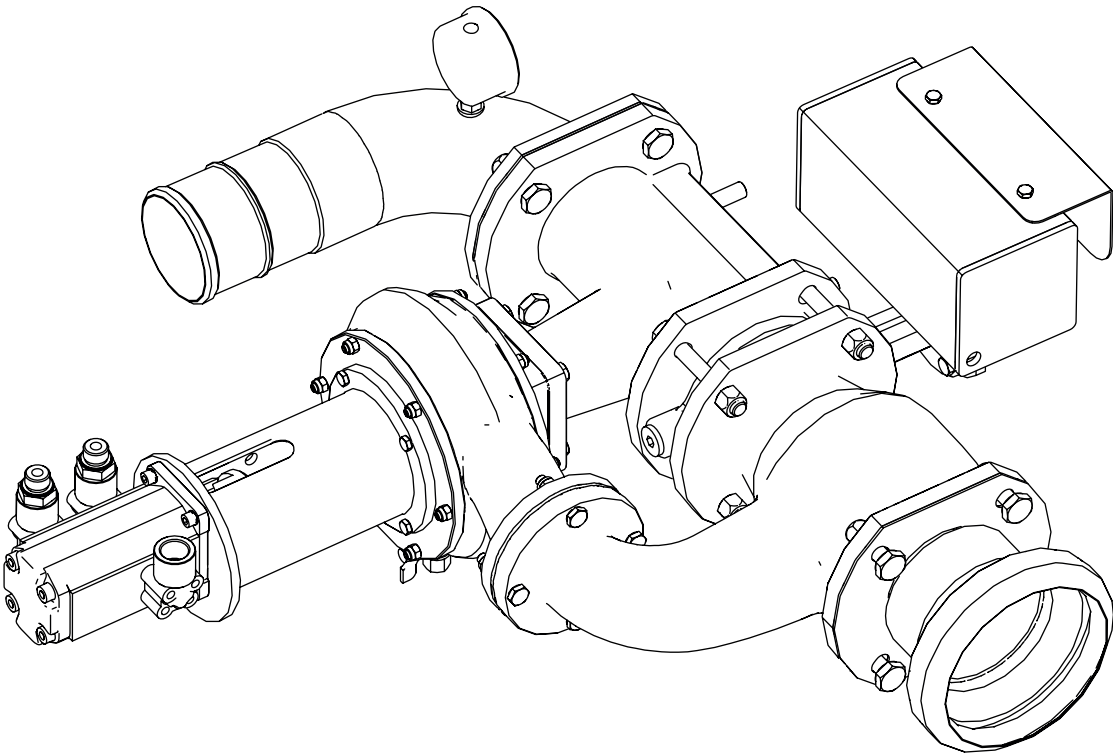

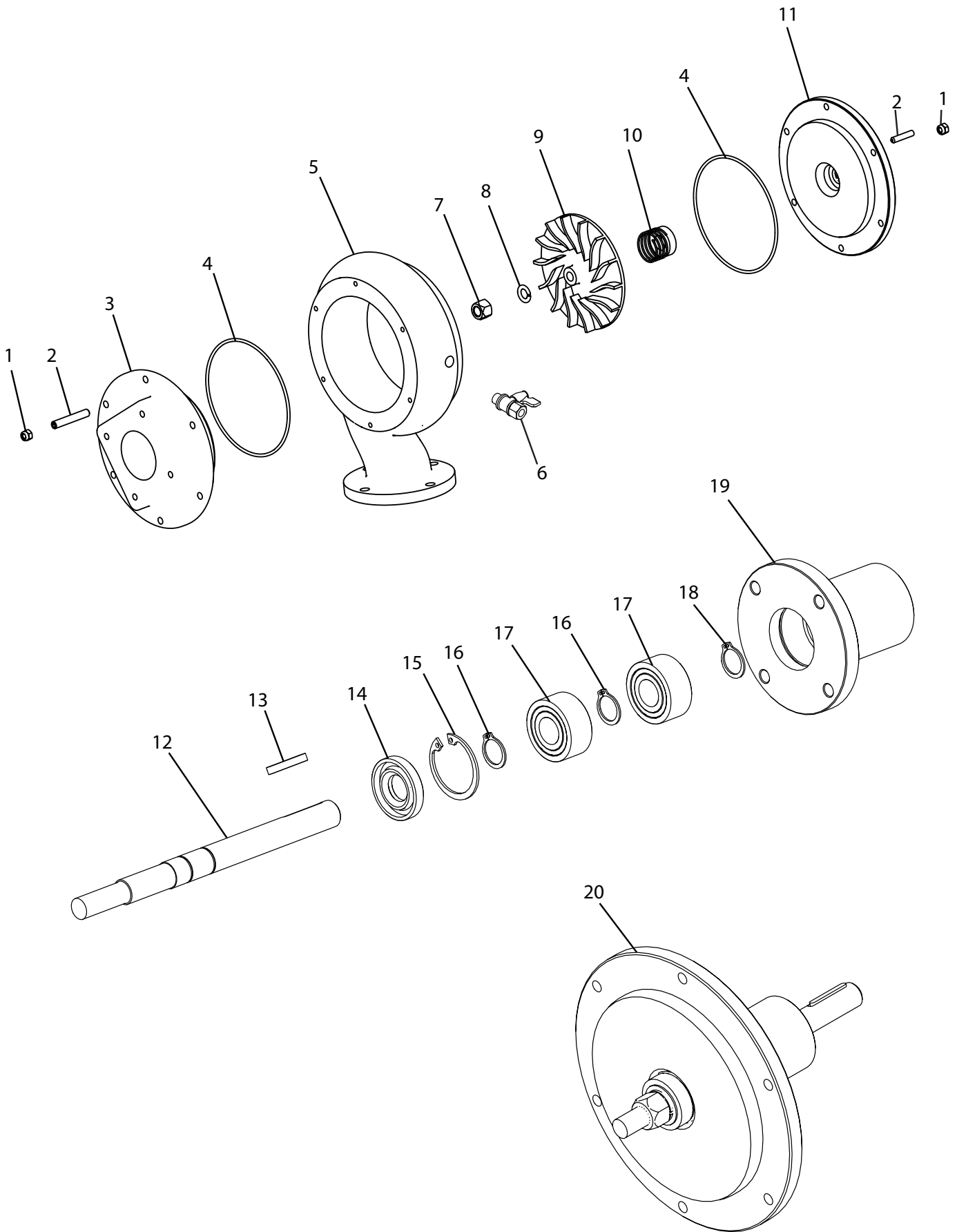

Item No.	Part No.	Qty	Description	Comments
1	095906	16	M6 Lock nut	
2	096506035	16	M6 x 35 Support bolt Pinol	
3	13000086	1	Upper flange turbine for top pipe	
4	195211	2	O-ring Cover seal	
5	195001	1	Turbine housing	
6	195010	1	Ball valve	
7	096012	1	M12 Nut	
8	096112	1	M12 Spring washer	
9	195031	1	Impeller	
10	P195201	1	Shaft seal for turbine	
11	195018	1	Packing block cover 20/50	
12	195036	1	Shaft	
13	195255	1	Key	4 x 4 29
14	195050	1	Sealing ring	
15	701035	1	Retaining ring Int.	
16	700015	2	Retaining ring Ext.	
17	195220	2	Front bearing	
18	517715	1	Clamping ring	
19	195013	1	Bearing housing	
20	195500	1	Turbine cover complete	
21	195000V	1	Complete turbine.	

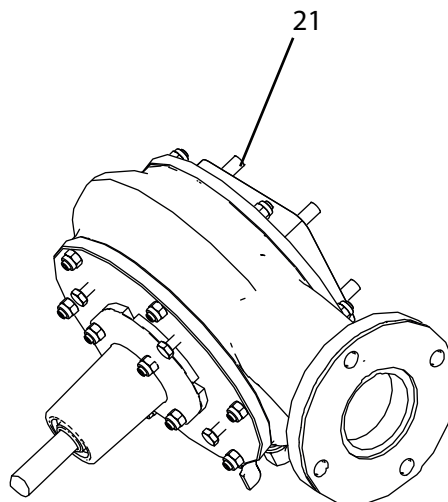

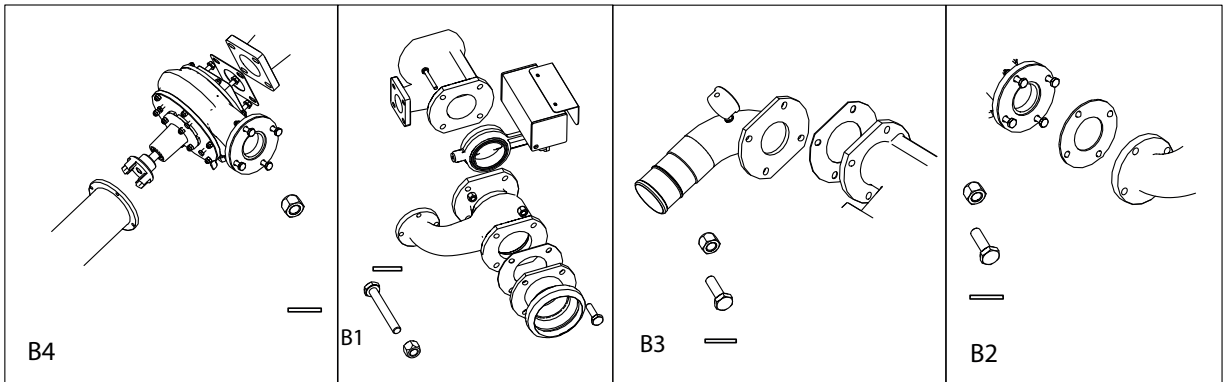
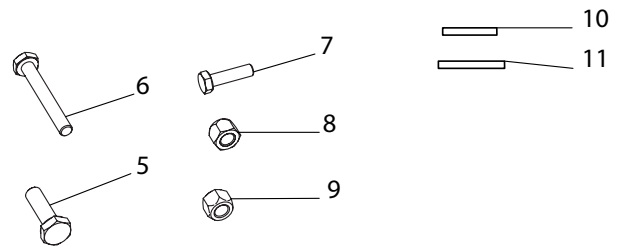
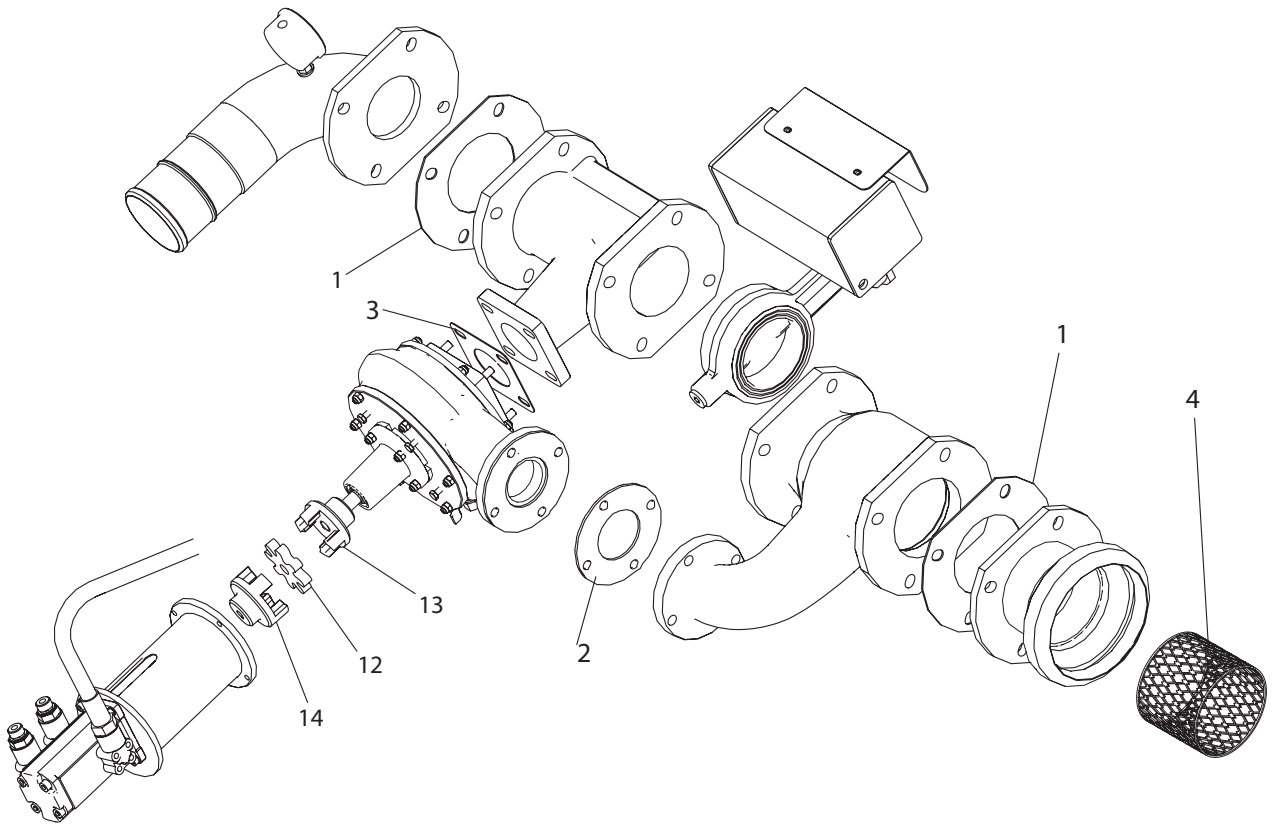

Item No.	Part No.	Qty	Description	Comments
1	631109	2	Flange gasket	
2	522085	1	Flange gasket	
3	631955	1	Flange gasket	
4	1005753	1	Filter	
5	021008045	4	M8 x 45 Steel bolt	B2
6	021010095	4	M10 x 95 Steel bolt	B1
7	022210040	8	M10 x 40 Steel set bolt	B1 & B3
8	040408	12	M8 Steel nut	B2 & B4
9	040410	12	M10 Steel nut	B3 & B1
10	763908	16	M8 Riplock	B2 & B4
11	763910	24	M10 Riplock	B3 & B1
12	1007470	1	Rubber for coupling	
13	1007460	1	Claw coupling Turbine	
14	1007450	1	Claw coupling Oil motor	

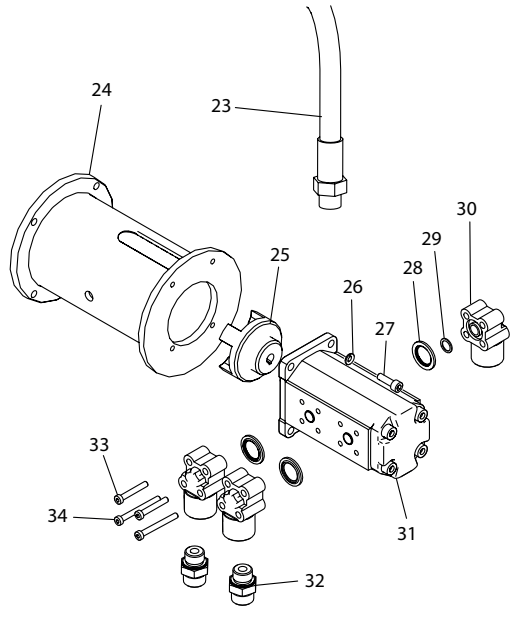
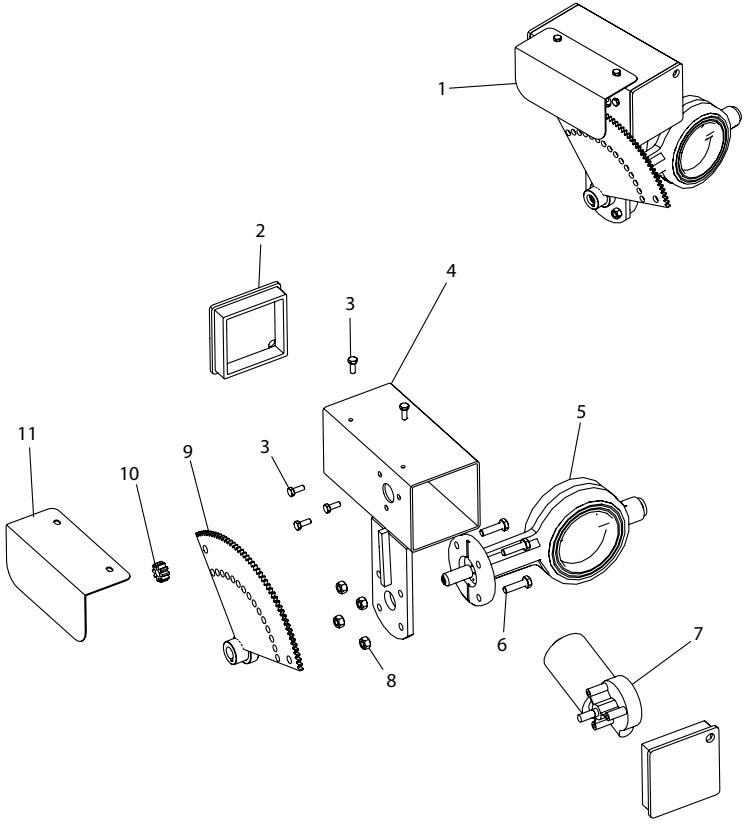
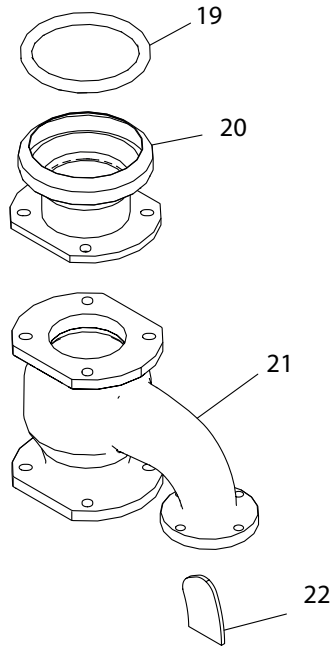
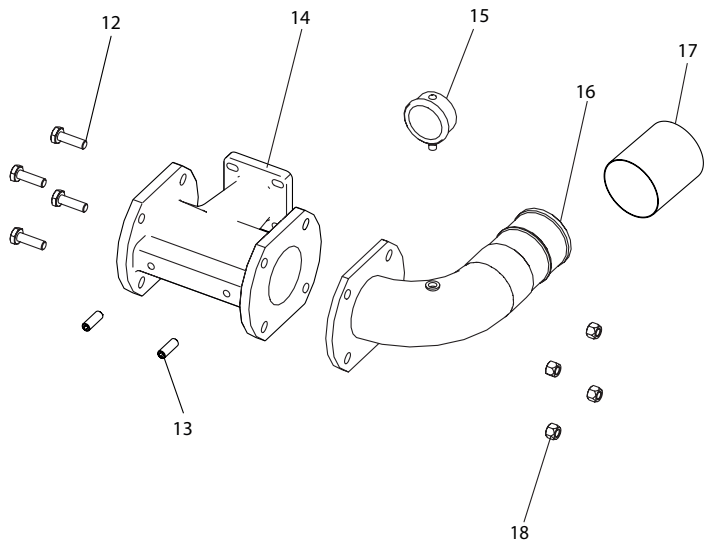

Item No.	Part No.	Qty	Description	Comments
1	1007230	1	Comp Motor valve	
2	1007175	2	End plug for motor valve	
3	022206016	3	M6 x 16 Steel set bolt	
4	1007171	1	Motor housing for motor valve	
5	1007250	1	Butterfly valve	
6	022208030	4	M8 x 30 Steel set bolt	
7	1007180	1	Motor for valve	
8	040408	4	M8 Steel nut	
9	1007195	1	Gear for valve	
10	1007190	1	Gear for electric motor	
11	1007185	1	Guard for motor valve	
12	021012040	4	M12 x 40 Steel bolt	
13	763764	2	M12 x 50 Int. hex	
14	33000227	1	Outlet pipe for turbine	
15	1001163	1	Manometer glycerine	
16	1009324	1	Flange with bend	
17	16050210	1	Soft hose no. per running metre	500 mm
18	040412	4	M12 Steel nut	
19	14050043	1	Rubber ring	
20	1009328	1	Flange with HK cup	
21	33000226	1	Base pipe for turbine	
22	13000085	1	Aerator	
23	1008605	1	Hydraulic hose 1/2	
24	1007110	1	Flange for pump	
25	1007450	1	Coupling part	
26	056206	4	M6 Spring washer	
27	030506020	4	M6 x 20 Int. hex	
28	552024	3	Sealing ring 1/2	
29	2.62x15.08	3	O-ring	
30	1007420	3	Flange for oil pump	
31	1010944	1	Dual pump	
32	1007726	2	Nipple 1/2	
33	030506030	6	M6 x 30 Int. hex	
34	030506040	6	M6 x 40 Int. hex	

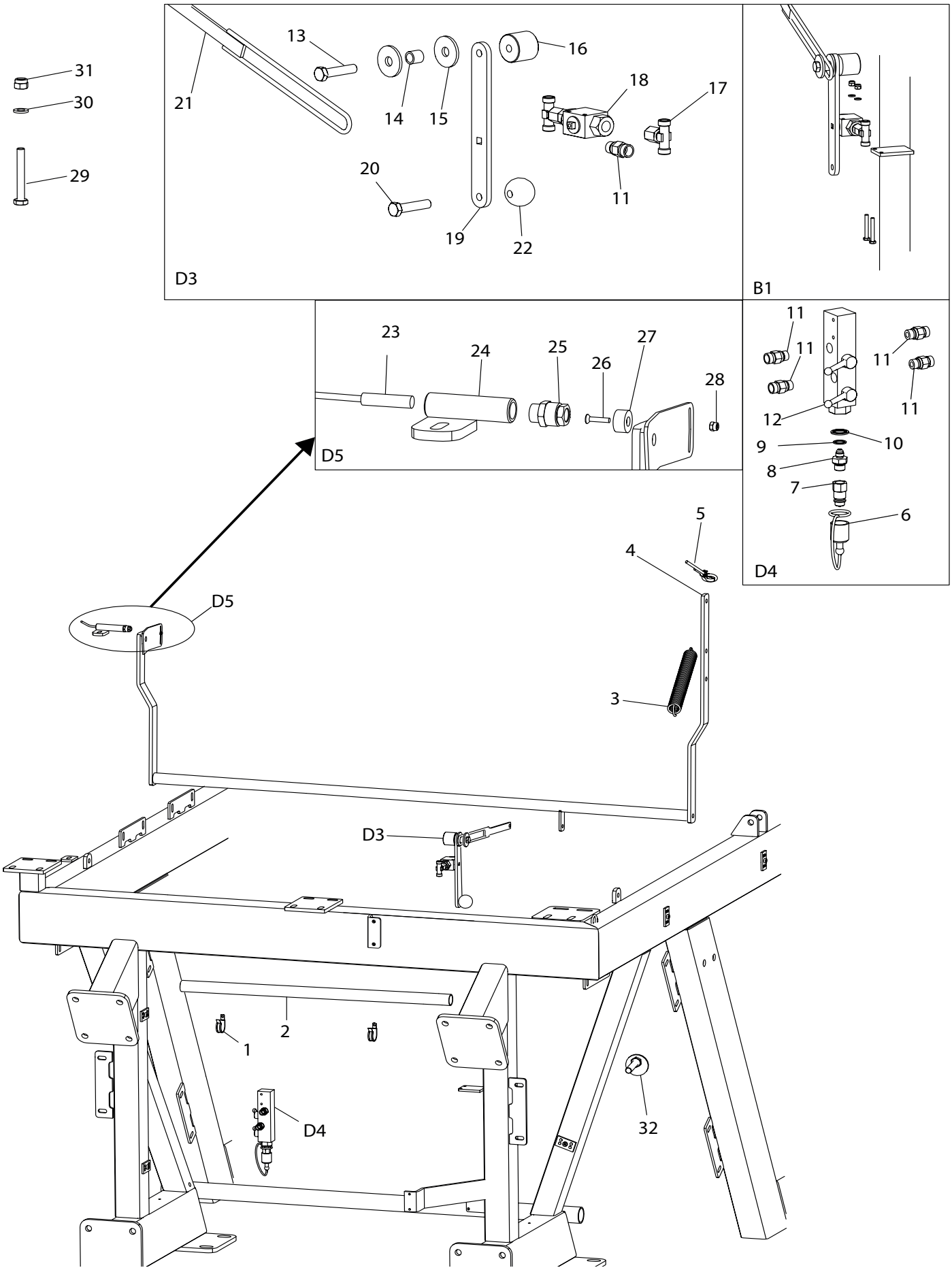

Item No.	Part No.	Qty	Description	Comments
1	1007770	1	Pipe bracket	
2	1009660	1	Plastic pipe for cables	
3	2003929	1	Spring	
4	2006224	1	Miswinder	
5	1007812	1	Cable Ø5 x 7600 mm	
6	801711	1	Plastic plug	
7	801710	1	Oil coupling	
8	1007538	1	Nipple	
9	552025	1	Sealing ring	
10	552024	1	Ø20 mm Gasket	
11	1007724	6	Nipple	
12	1010755	1	2-way ball valve	
13	022212055	1	M12 x 55 Set bolt	
14	109101	1	Spacer	
15	05401250	1	M12 round washer	
16	1007511	1	Wheel chock	
17	1007518	1	Tee	
18	1007510	1	Ball valve	
19	1008335-1	1	Lever for miswinder	
20	022212035	1	M12 x 35 Set bolt	
21	1009260	1	Stop bar	
22	763300	1	Ball lever	
23	1007560	1	Sensor	
24	1008265	1	Pipe for end stop sensor	
25	1005535-1	1	Cable coupling	
26	034604020	1	M4x20 Machine screw	
27	1005530	1	Magnet	
28	044004	1	M4 Lock nut	
29	022206045	2	M6 x 45 Set bolt	
30	051006	2	M6 Plain washer	
31	044006	2	M8 Lock nut	
32	1009350	2	Stop bolt for miswinding bar	

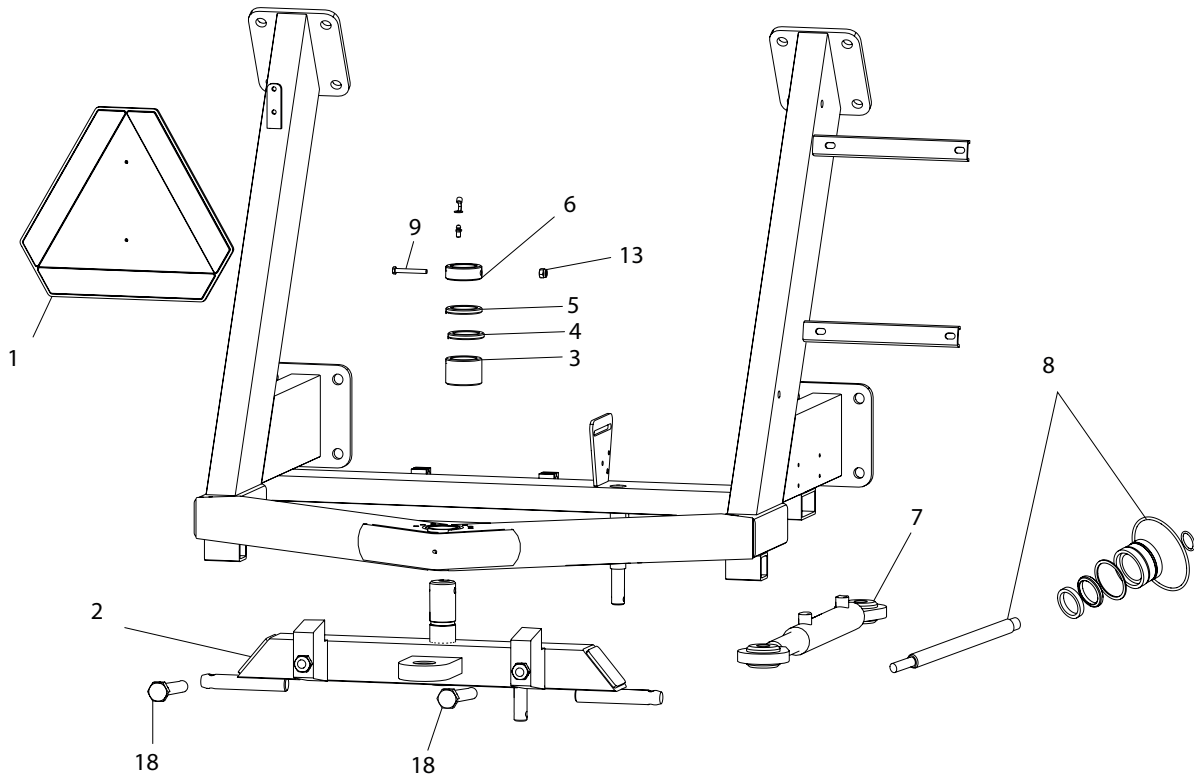
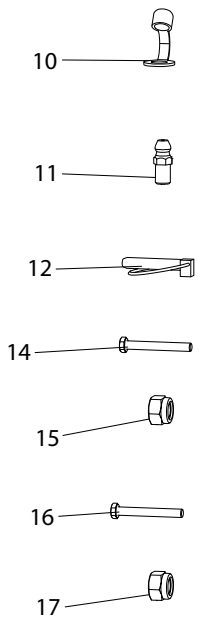
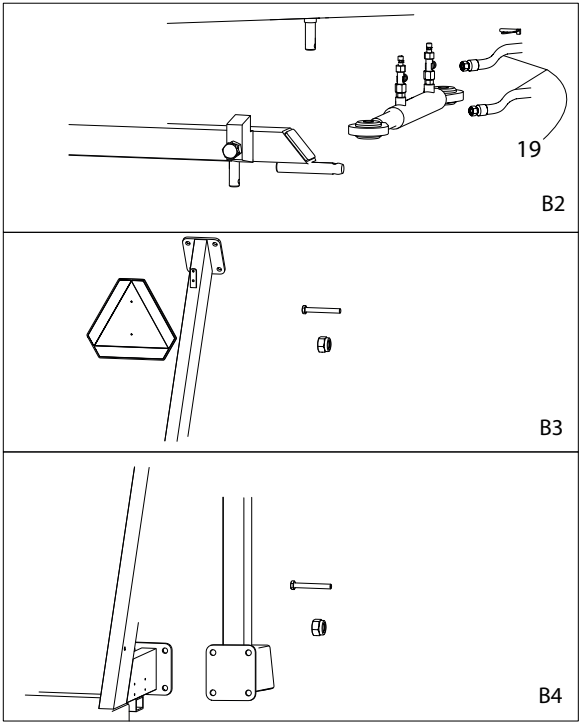

Item No.	Part No.	Qty	Description	Comments
1	1008966	1	Warning triangle	
2	1008250	1	Rear drawbar Comp	
3	1008101	1	Bushing	
4	895630	7	Support ring 1 mm	
5	1008198	7	Spacer washer 2 mm	
6	1008195	1	Stop ring	
7	1008585	1	Cylinder for forced steering	
8	1008585-1	1	Gasket set for cylinder	
9	022210080	1	M10 x 80 Steel set bolt	
10	761286-2	1	Lubrication cap	
11	761286	1	Grease nipple	
12	763642	1	Tractor split pin	
13	044010	1	M10 Lock nut	
14	022216045	16	M16 x 45 Steel set bolt	
15	044008	2	M8 Lock nut	
16	022208016	2	M8 x 16 Steel set bolt	
17	040416	16	M16 Lock nut	
18	022224060	2	M24 x 60 Set bolt	
19	1008614	2	Hyd. Hose for forced steering	B2 the same

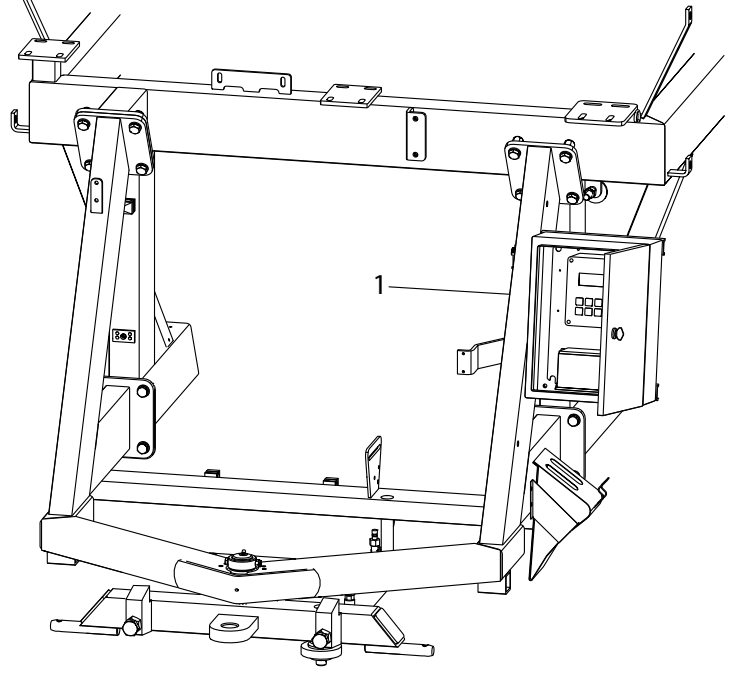
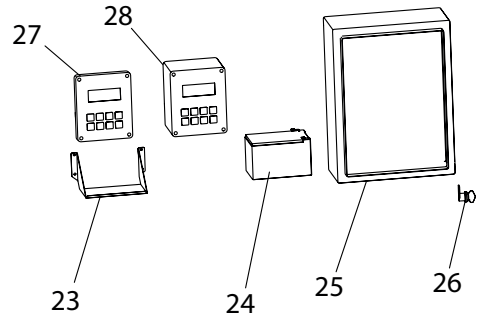
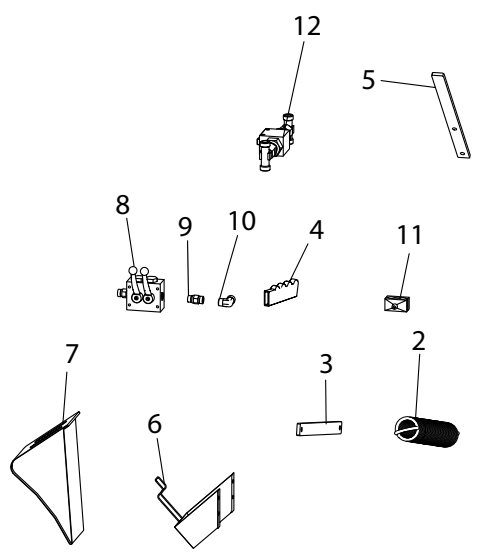
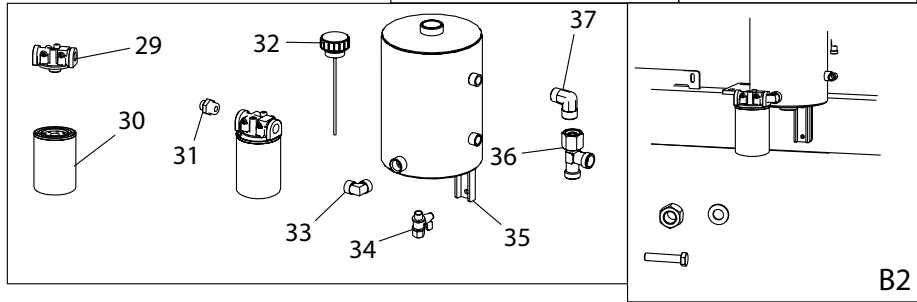
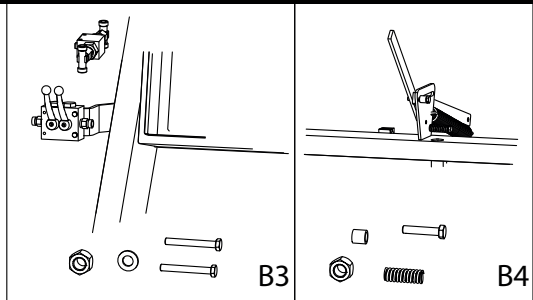
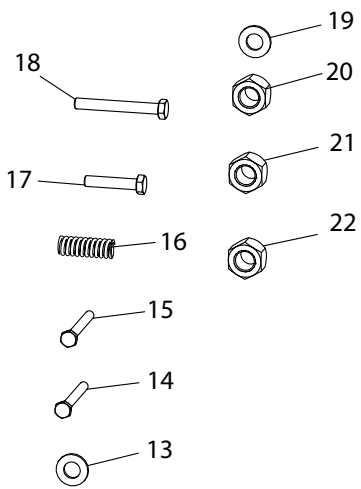

Item No.	Part No.	Qty	Description	Comments
1	1009150	1	Rear drawbar	
2	761274	1	Drawbar spring	
3	2004055-1	1	Release arm	
4	680009	1	Rubber grip	
5	1009250	1	Lever for decoupling	
6	2004913	2	Holder for stop wedge	
7	2004912	2	Stop wedge	
8	1010750	1	Ball valve for dual pump	
9	1007724	1	Nipple	
10	1008622	1	Angle	
11	1007514	2	Hose carrier	
12	1007510	1	Ball valve for decoupling	
13	051006	4	M6 Plain washer	B3
14	022206045	2	M6 x 45 Steel set bolt	B3
15	022210030	2	M10 x 30 Steel set bolt	B2
16	1009252	1	Compression spring for coupling	
17	022210080	1	M10 x 80 Steel set bolt	B4
18	021006055	2	M6 x 55 Steel bolt	B3
19	763910	4	M10 Riplock	B2
20	044006	4	M6 Lock nut	B3
21	040410	3	M10 Steel nut	B4 & B2
22	040416	2	M16 Steel nut	
23	1007590	1	Plate for battery	
24	1005521	1	Battery	
25	1007578	1	Electric box	
26	1007584	1	Lock for box	
27	1007549-8	1	Exchanger Prog Rain	
28	1007549-7	1	Prog. Rain.	
29	1007484	1	Filter housing	
30	1007482	1	Hydraulic filter	
31	1007526	1	Nipple	
32	1007500	1	Tank Cover	
33	1007536	3	Angle cyl 3/4 x 3/4	
34	195010	1	Ball valve	
35	1007490	1	Tank	
36	1007531	1	Tee	
37	1007540	1	Angle	

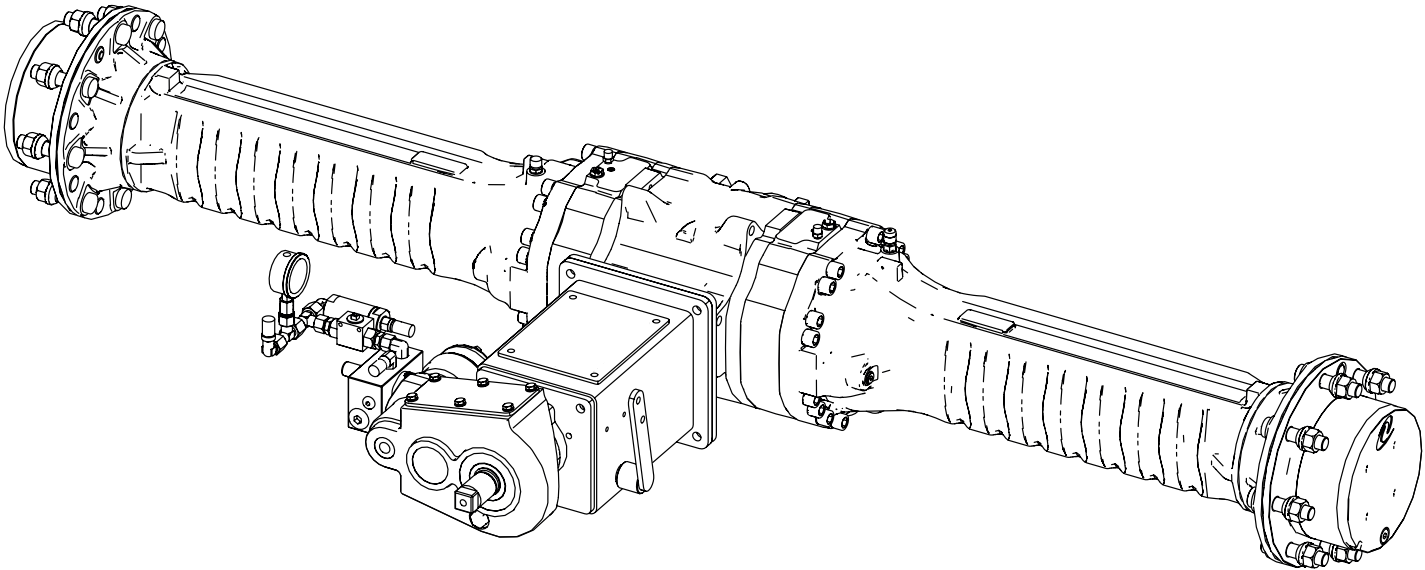

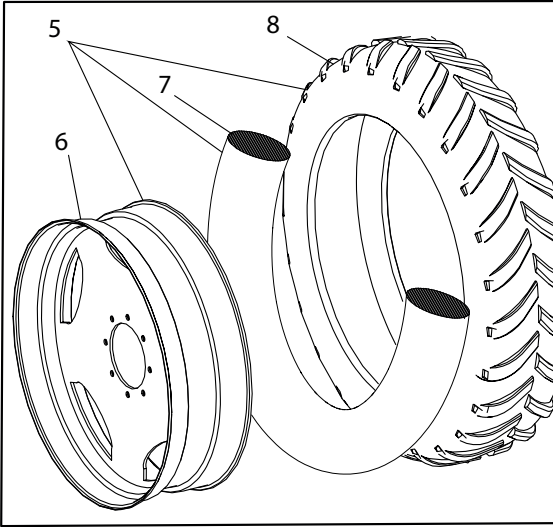
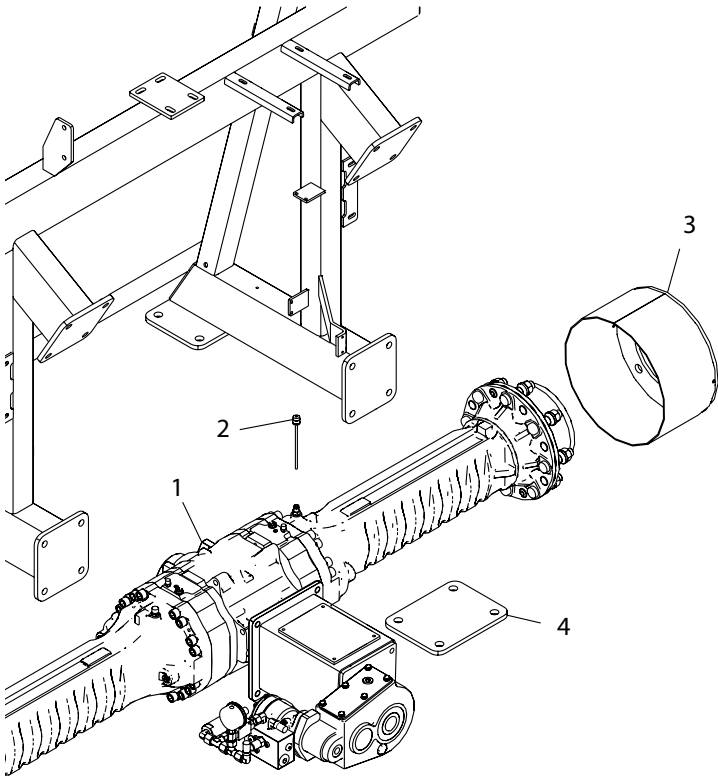
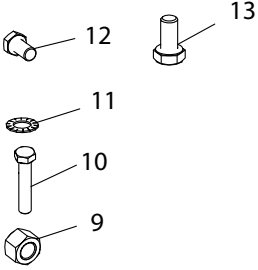
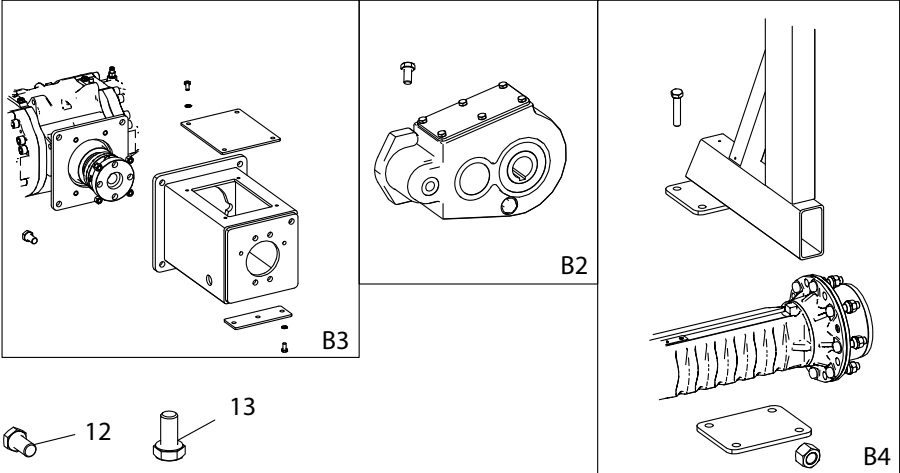

Item No.	Part No.	Qty	Description	Comments
1	1009492	1	Rear axle assembly	1800 mm
1	1009493	1	Rear axle assembly	2050 mm
2	2002813	1	Dipstick	
3	1009285	2	Tube	
4	2002039-1	2	Bracket for rear axle assembly	
5	1008769	1	Rear wheel Comp Left Track width 2000 mm	
5	1008769-2	1	Rear wheel Comp Right Track width 2000 mm	
5	2007429-2	1	Rear wheel Comp Right Track width 1800 mm	
5	2007429	1	Rear wheel Comp Left Track width 1800 mm	
6	2007776	2	Rim Track width 2000 mm	
6	2007349	2	Rim Track width 1800 mm	
7	1008715	2	Hose	
8	1008710	2	Tyres	
9	044020	8	M20 Lock nut	B4
10	021020220	8	M20 x 220 Steel bolt	B4
11	763908	6	M8 Riplock	B3
12	022216030	4	M16 x 30 Set bolt	B2
13	022208016	6	M8 x 16 Set bolt	B3

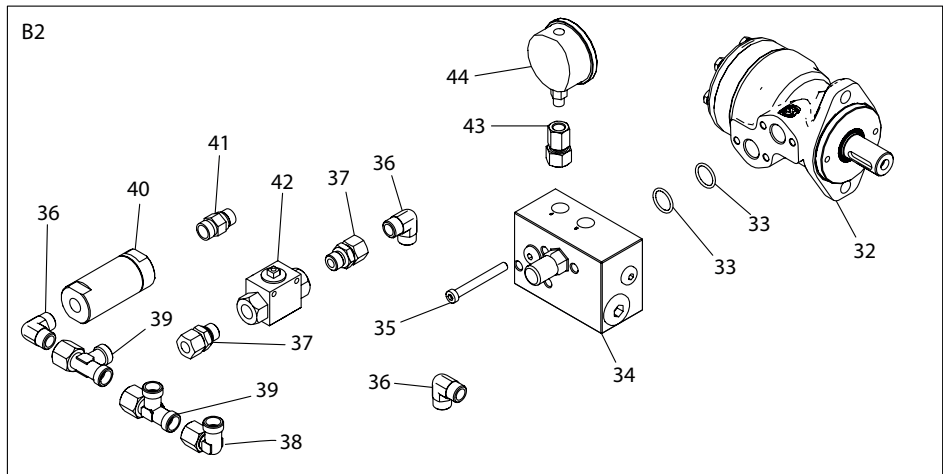
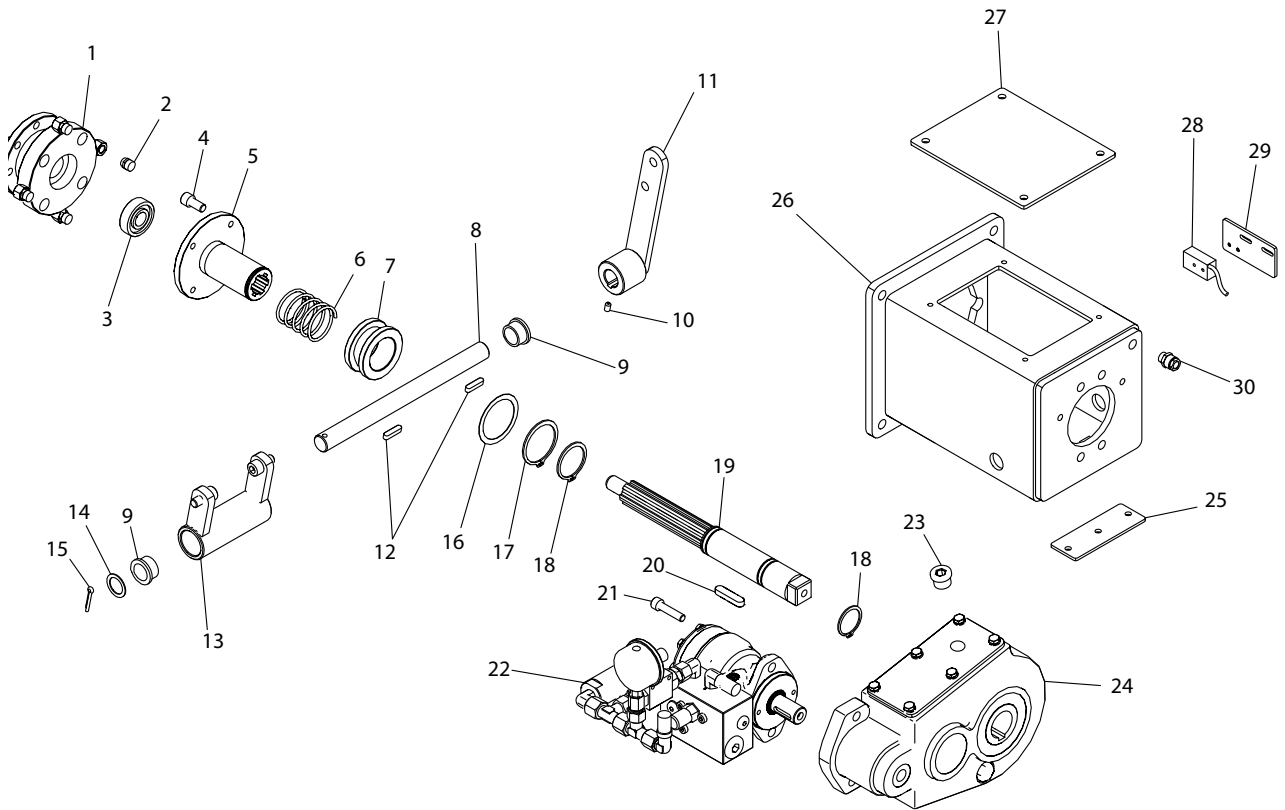
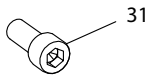
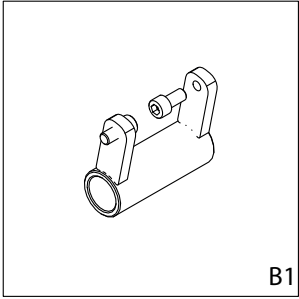

Item No.	Part No.	Qty	Description	Comments
1	1009215	1	Hub for magnet	
2	1007571	4	Magnet	
3	1009216	1	Support bearing	
4	763570	4	M12 x 25 Unbraco bolt	
5	1009220	1	Coupling hub	
6	1009227	1	Compression spring	
7	1009225	1	Shift sleeve	
8	1009235	1	Shaft	
9	1009203	2	Bushing shaft	
10	033006008	2	M6x8 Int. hex	
11	1009245	1	Shift arm	
12	641625	2	Key	
13	1009240	1	Shift fork	
14	658421		Shim ring Ø20x28x1	
15	761010	1	Split pin	
16	1009222	1	Shim ring	
17	1009221	1	Retaining ring	
18	700040	2	Retaining ring	
19	1009230	1	Shaft for coupling	
20	641850	1	Key	
21	763572	2	M12 x 45 Unbraco bolt	
22	B2			
23	1007728-5	1	Plug for flat gear	
24	1009500	1	Flat gear	
25	1009207	1	Base cover	
26	2002057	1	Coupling housing	
27	1009205	1	Cover	
28	1007561		Dual sensor with 5m cable	
29	1009255		Bracket for coupling housing sensor	
30	1005535-1		Cable coupling	
31	763770	2	M10 x 22 Unbraco bolt	B1
32	1007443	1	Oil motor	
33	2.4x21.3	2	O-ring	
34	1013950	1	Valve block	
35	030008070	4	Bolt	
36	1007544	3	Angle	
37	890414	2	Nipple straight	
38	1008622	1	Angle	
39	1007531	2	Tee	
40	1010970	1	Filter	
41	1007724	1	Nipple straight	
42	1007510	1	Ball valve	
43	1010979	1	Nipple straight	
44	761163-4	1	Manometer	

FLADGEAR

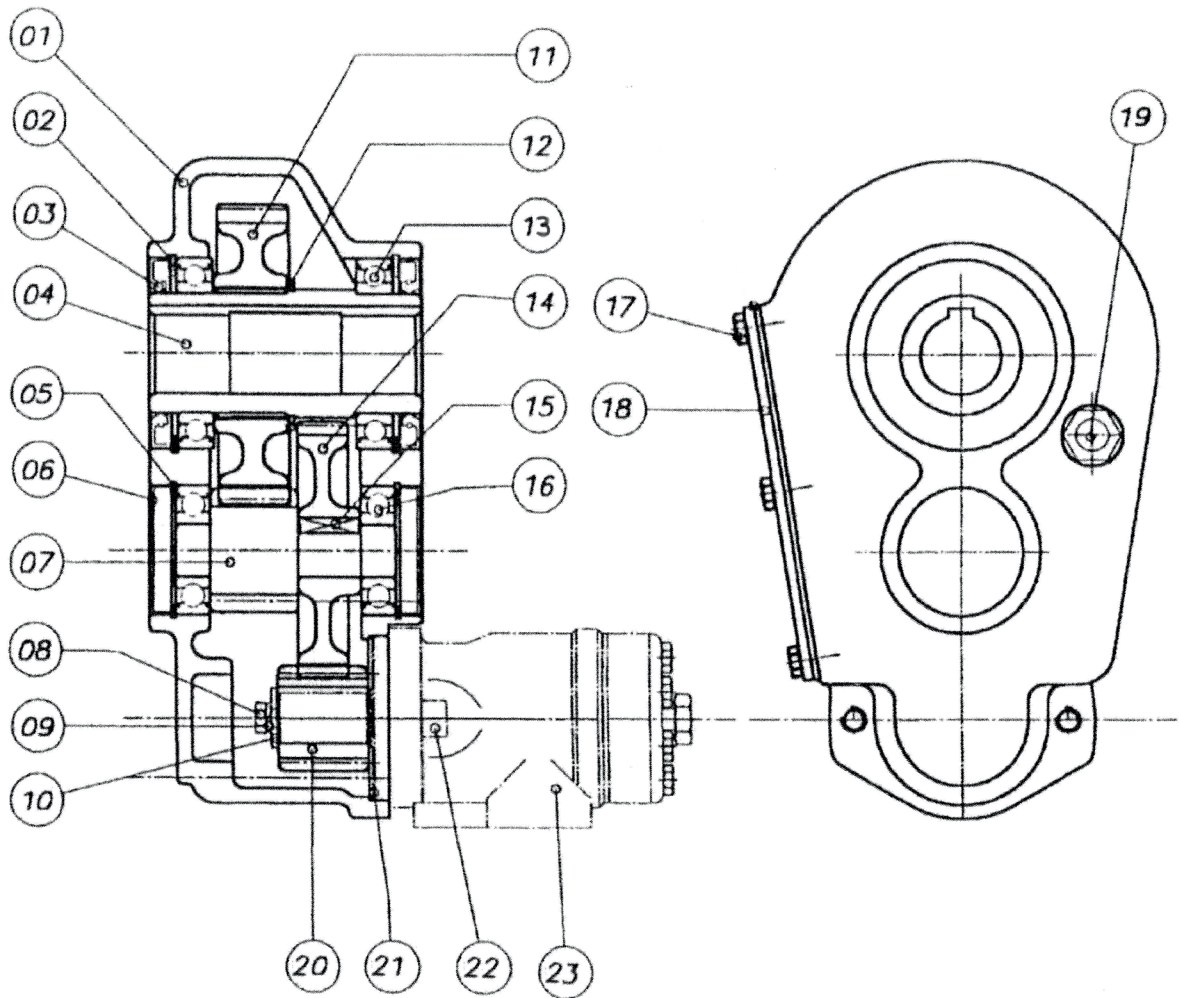

Item No.	Part No.	Qty	Description	Comments
1	1009500	1	Gear comp	
2	1009504	1	Retaining ring 95 mm	
3	1009505	1	Sealing ring Ø60/95x10	
4	1009506	1	Hollow shaft Ø40	
5	1009507	1	Retaining ring 62 mm	
6	1009508	2	Cover Ø62	
7	1009509	1	Shaft/Gear	
8	1009510	1	Bolt with int. Hex M8 x 20	
9	1009511	1	Washer	
10	1009512	1	Spring washer	
11	1009513	1	Gear	
12	1009514	1	Retaining ring 65 mm	
13	1009515	2	Bearing	
14	1009516	1	Gear	
15	1009517	1	Key	8 x 7 x 30
16	1009518	2	Bearing	6305
17	1009520	6	M8 x 16 mm	
18	1009521	1	Cover	
19	1009522	1	Sight glass	1/2
20	1009523	1	Gear	
21	1009524	1	Gasket	
22	1009529	1	Int. hex M12 x 35	
23	1007443	1	Oil motor	

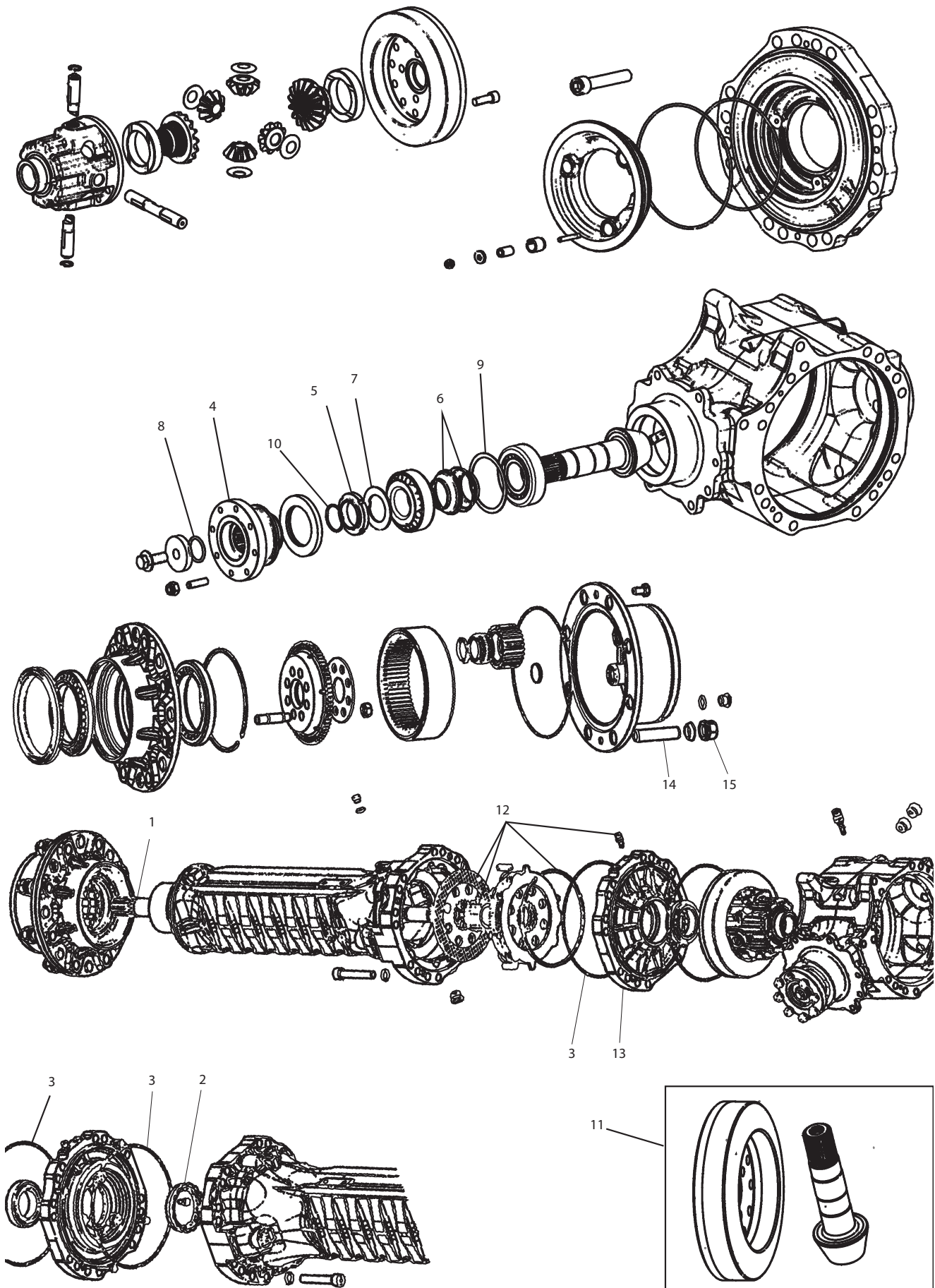

Item No.	Part No.	Qty	Description	Comments
1	1009570	2	Shaft FM4550H	
2	1009571	2	Ring nut	
3	1009572	4	O-ring 3.53 x 240.89	
4	1009573	1	Cardan flange	
5	1009574	1	Ring nut M40	
6	1009575	2	Spring cup	
7	1009576	1	Lock washer	
8	1009577	1	O-ring 3.53 x 29.75	
9	1009578	1	Shim washer Ø76	
10	1009579	1	Retaining ring without ears	
11	1009580	1	Crown/Pinion	
12	1009581	2	Brake Repair Set	
13	1009582	2	Pressure flange for brake	
14	1009455-6	18	Hub bolt M22 x 50	
15	1009456-6	18	Hub nut	

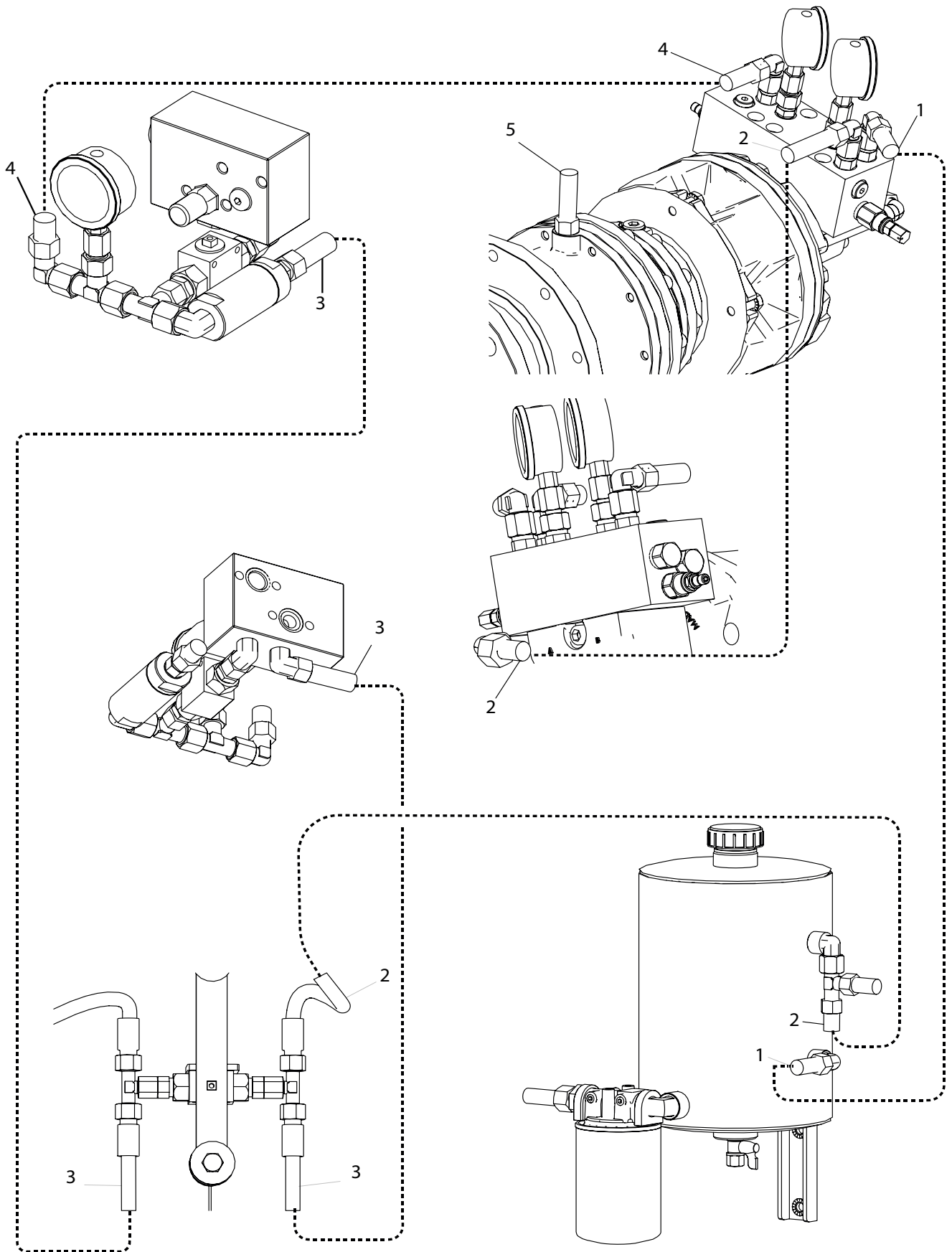

Side 1-2

Item No.	Part No.	Qty	Description	Comments
1	1010987	1	Hose 3/8 x 2800 mm	
2	1008612	1	Hose 3/8 x 600 mm	
3	1008601	2	Hose 3/8 x 1600 mm	
4	556010	1	Hose 3/8 x 4000 mm	
5	1010981	1	Hose 1/4 x 1230 mm	

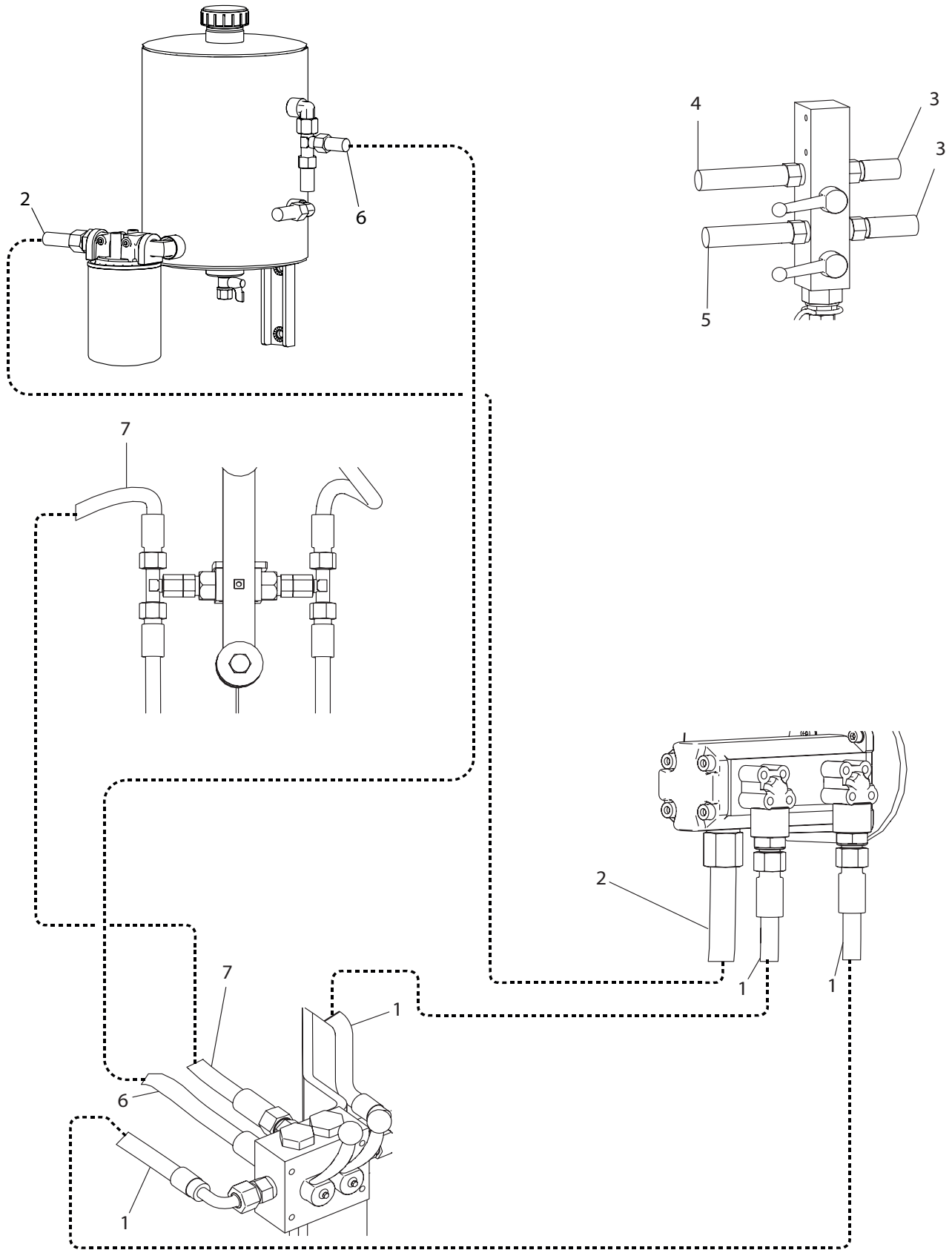

Side 2-2

Item No.	Part No.	Qty	Description	Comments
1	1008601	3	Hose 3/8 x 1600 mm	
2	1008605	1	Hose 1/2 x 750 mm	
3	1008614	2	Hose 3/8 x 4900 mm	
4	1007515	1	Hose 3/8 x 750 mm	
5	1008610	1	Hose 3/8 x 400 mm	
6	1008609	1	Hose 3/8 x 1200 mm	
7	1008600	1	Hose 3/8 x 1050 mm	
8	1007724	4	Nipple straight 3/8 x Ø12	
9	1007531	4	Tee Ø12	
10	1007499	4	Nipple for air screw	
11	1007505	4	12 mm union nut	
12	1007501	4	Vent screw	
13	1007502	4	Cap for vent screw	

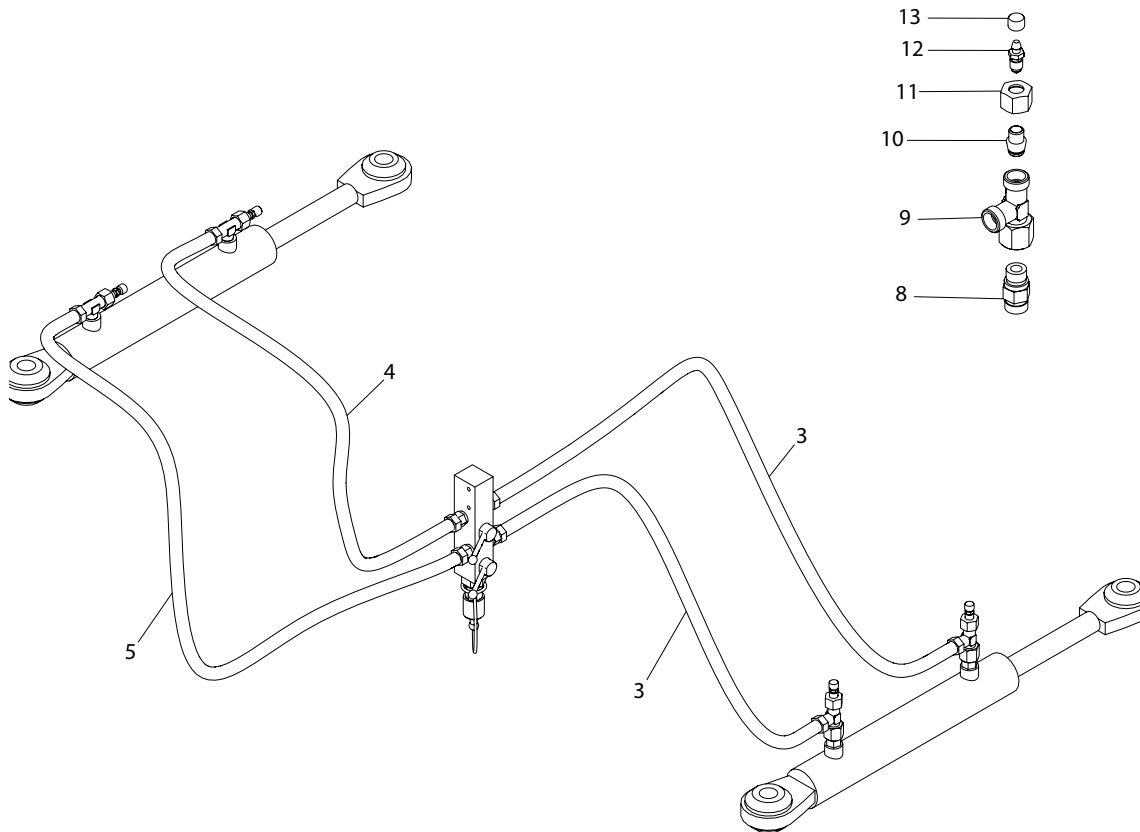

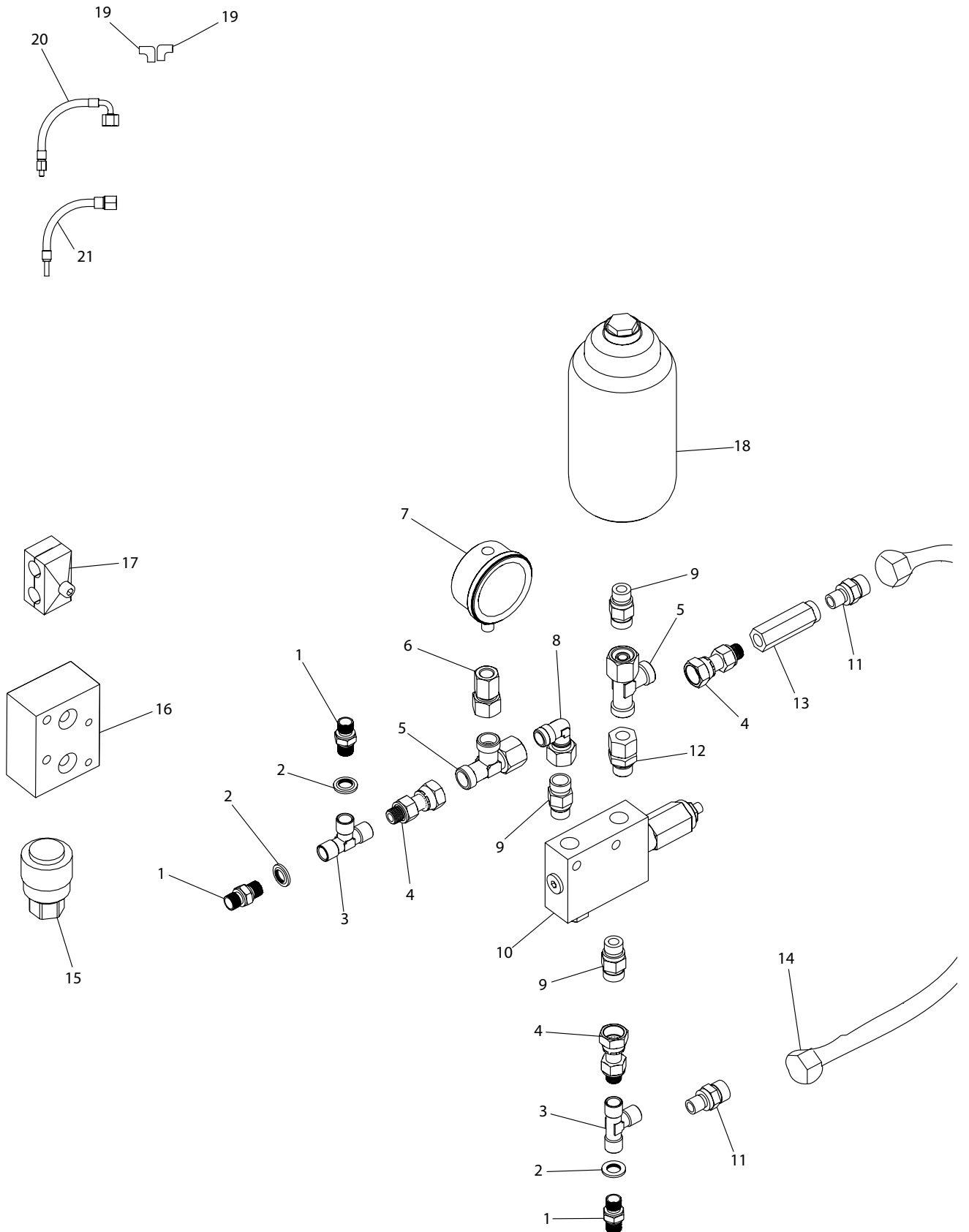

Item No.	Part No.	Qty	Description	Comments
1	1013825	3	Nipple	
2	552026	3	Sealing ring 1/4	
3	1013814	2	Tee 1/4 x 1/4 x 1/4 int.	
4	1010976	3	Nipple straight 1/4	
5	1007531	2	Tee Ø12 Fixed bypass X Ø12 x Ø12	
6	1010979	1	Nipple straight for manometer	
7	761163-4	1	Manometer	
8	1008622	1	Adjustable angle Ø12	
9	1007724	3	Nipple straight 3/8	
10	1013835	1	Brake valve	
11	1010978	2	Nipple straight 1/4 x Ø12	
12	890414	1	Nipple straight 3/8 x Ø12 bypass Fixed bypass	
13	1210C055CA07	1	Check valve	
14	1008610	1	Hose 3/8 x 400 mm	
15	1013817	1	Brake Hyd. Coupling 1/2 int. thread	
16	2004448	1	Assembly block	
17	1007514	10	Hose carrier	
18	1013837	1	Accumulator for brakes	
19	1013845	2	Angle screw fitting	
20	1013843	1	Brake hose 3/16 x 500 mm	
21	1013842	1	Brake hose 3/16 x 650 mm	

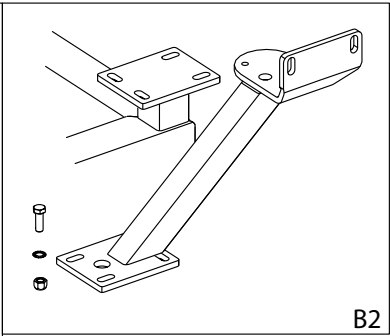
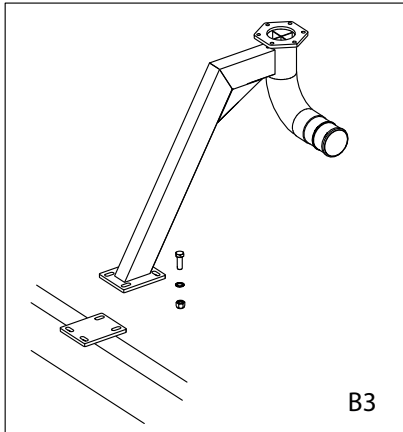

- 5
- 4
- 3

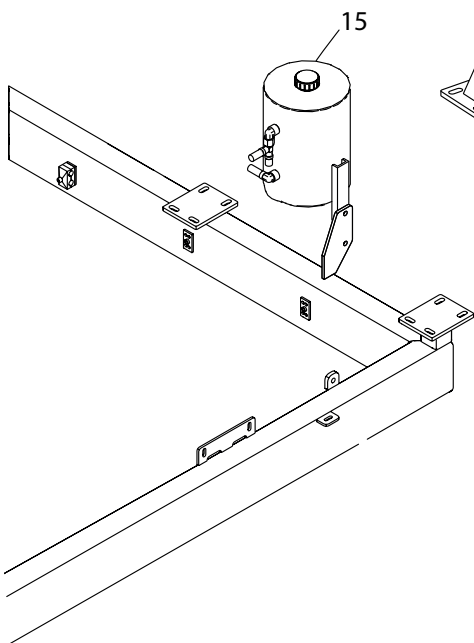
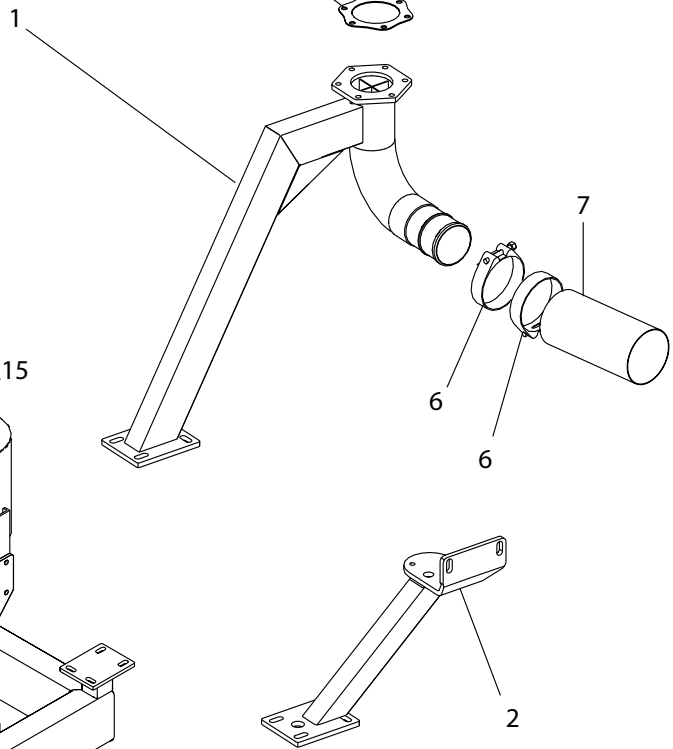
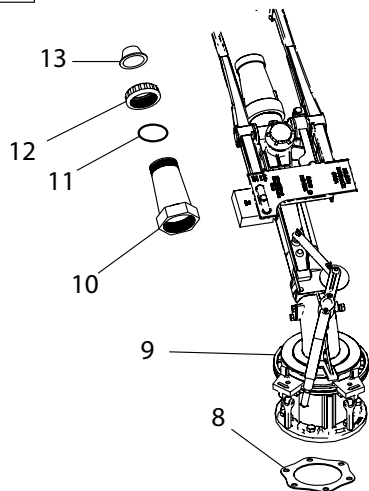

Item No.	Part No.	Qty	Description	Comments
1	1007655	1	Gun pipe	
2	1009120	1	Suspension for turbine	
3	040412	8	M12 Steel nut	B3 & B2
4	763912	16	M12 Riplock	B3 & B2
5	022212035	8	M12 x 35 Set bolt	B3 & B2
6	16200730	2	Hose clamp	
7	16050210	1	Hose 500 mm	
8	761614	1	Flange gasket	
9	770145	1	Gun	
10	7712781	1	150Tr Plastic body	
11	7712785	1	O-ring	
12	7712467	1	150Tr Plastic cap	
13	7712468-018	1	18 mm 150 tr plastic nozzle	
13	7712468-019	1	19 mm 150 tr plastic nozzle	
13	7712468-020	1	20 mm 150 tr plastic nozzle	
13	7712468-021	1	21 mm 150 tr plastic nozzle	
13	7712468-022	1	22 mm 150 tr plastic nozzle	
13	7712468-023	1	23 mm 150 tr plastic nozzle	
13	7712468-024	1	24 mm 150 tr plastic nozzle	
13	7712468-025	1	25 mm 150 tr plastic nozzle	
13	7712468-026	1	26 mm 150 tr plastic nozzle	
13	7712468-027	1	27 mm 150 tr plastic nozzle	
13	7712468-028	1	28 mm 150 tr plastic nozzle	
13	7712468-029	1	29 mm 150 tr plastic nozzle	
13	7712468-030	1	30 mm 150 tr plastic nozzle	
13	7712468-031	1	31 mm 150 tr plastic nozzle	
13	7712468-032	1	32 mm 150 tr plastic nozzle	
13	7712468-033	1	33 mm 150 tr plastic nozzle	
13	7712468-034	1	34 mm 150 tr plastic nozzle	
14	7712701	1	Complete nozzle	
15	1007490	1	Tank	

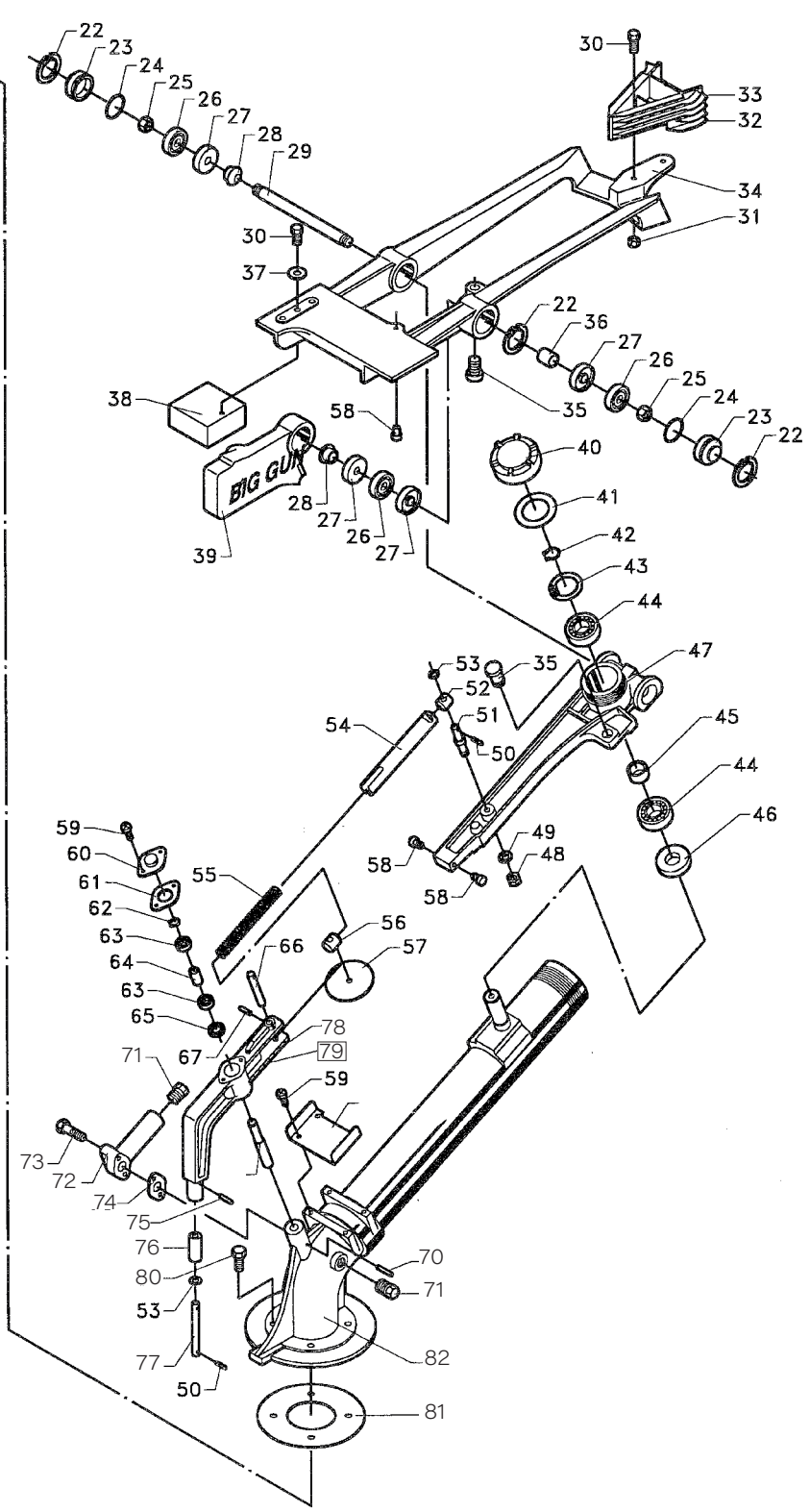
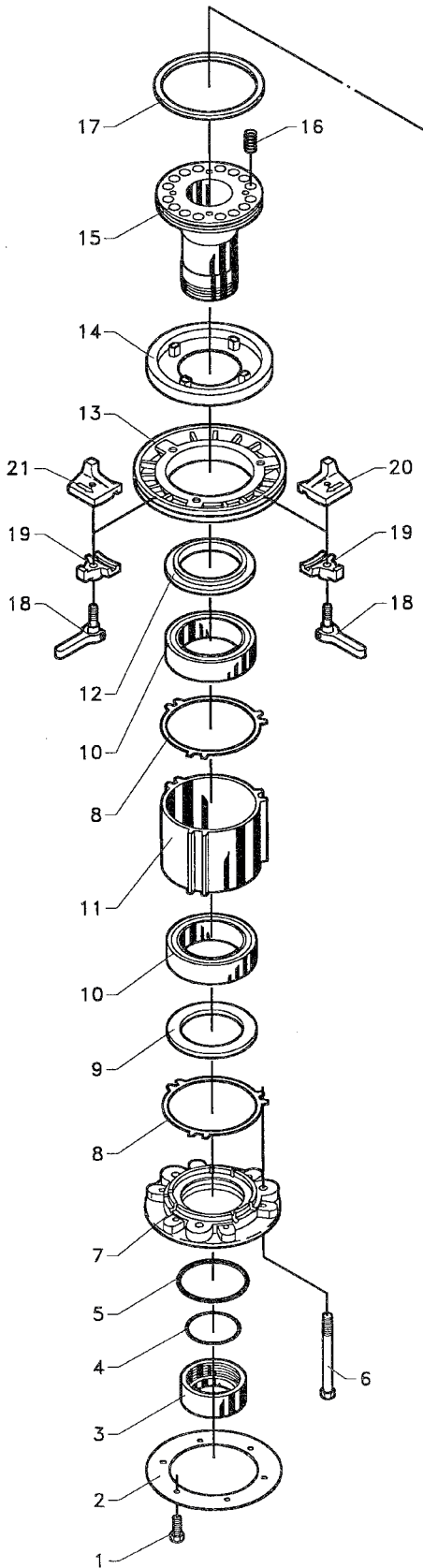

Item No.	Part No.	Qty	Description	Comments
1	776849	1	Bolt	
2	761614	1	Flange gasket for gun	
3	778402	1	Lock nut	
4	776548	1	O-ring	
5	778475	1	O-ring	
6	778462	3	Bolt	
7	778401	1	Base piece	
8	778461	2	Gasket	
9	778373	1	Sealing ring	
10	776253	2	Ball bearing	
11	778405	1	Bearing housing	
12	778372	1	Sealing ring	
13	778400	1	Brake disc	
14	778371	1	Brake lining	
15	778459	1	Bearing pipe	
16	778474	12	Spring	
17	778473	1	Sealing ring	
18	776849	2	Bolt	
19	776371	2	Bracket	
20	778432	1	Wheel chock Left	
21	778431	1	Wheel chock Right	
22	776565	3	Retaining ring	
23	776602	2	End cover	
24	776563	2	O-ring	
25	776603	2	Nut	
26	776598	3	Ball bearing	
27	776600	4	Sealing ring	
28	776607	2	Spacer pipe	
29	778465	1	Shaft	
30	776818	2	Bolt	
31	776060	2	Nut	
32	778354	1	Drive blade	
34	778364	1	Drive arm	
35	778139	2	Rubber stop	
36	778327	1	Spacer pipe	
37	776070	1	Flat washer	
38	778433	1	Weight block	
39	778366	1	Counterweight	
40	778233	1	Cover	
41	778272	1	Gasket	

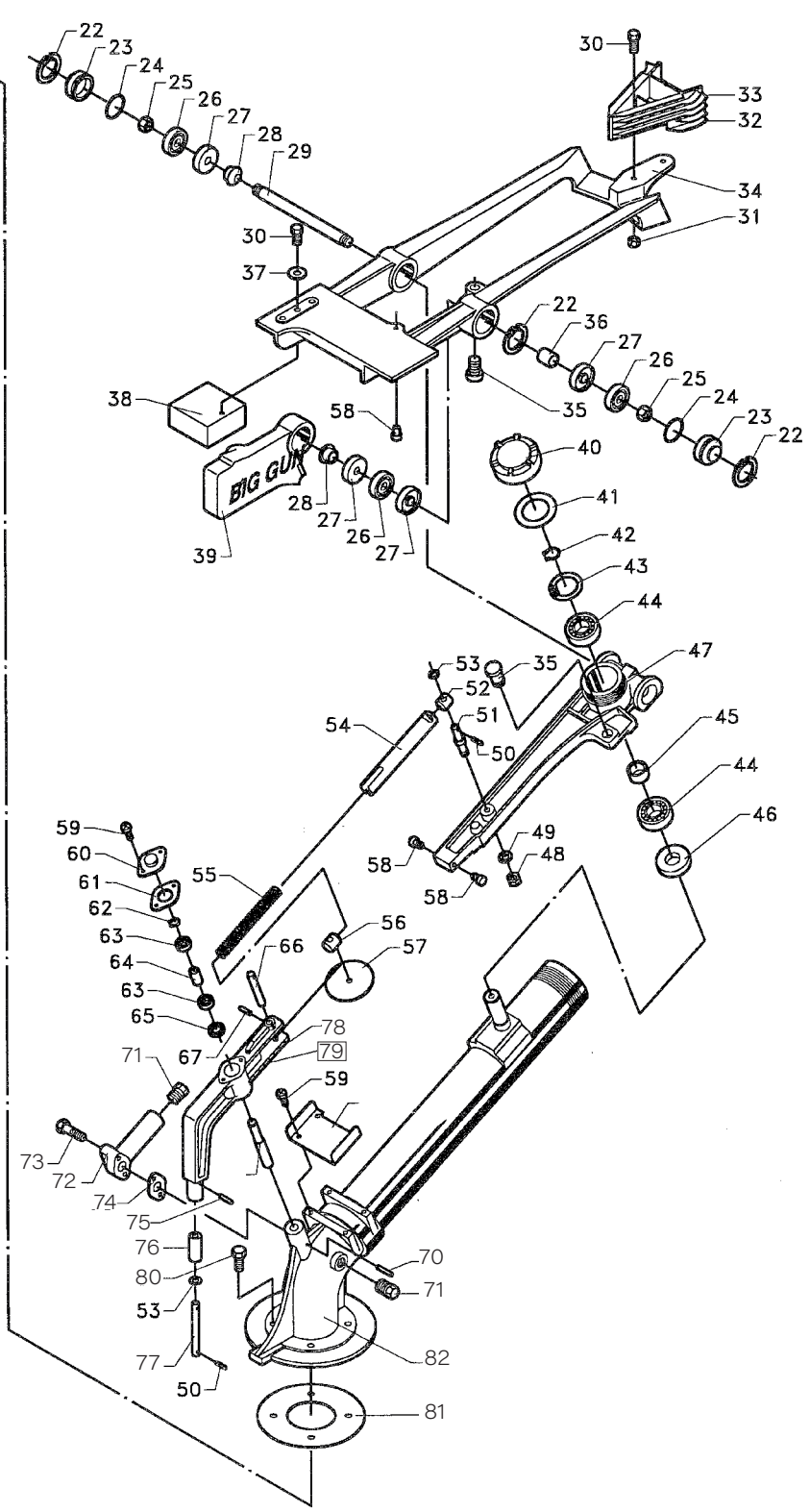
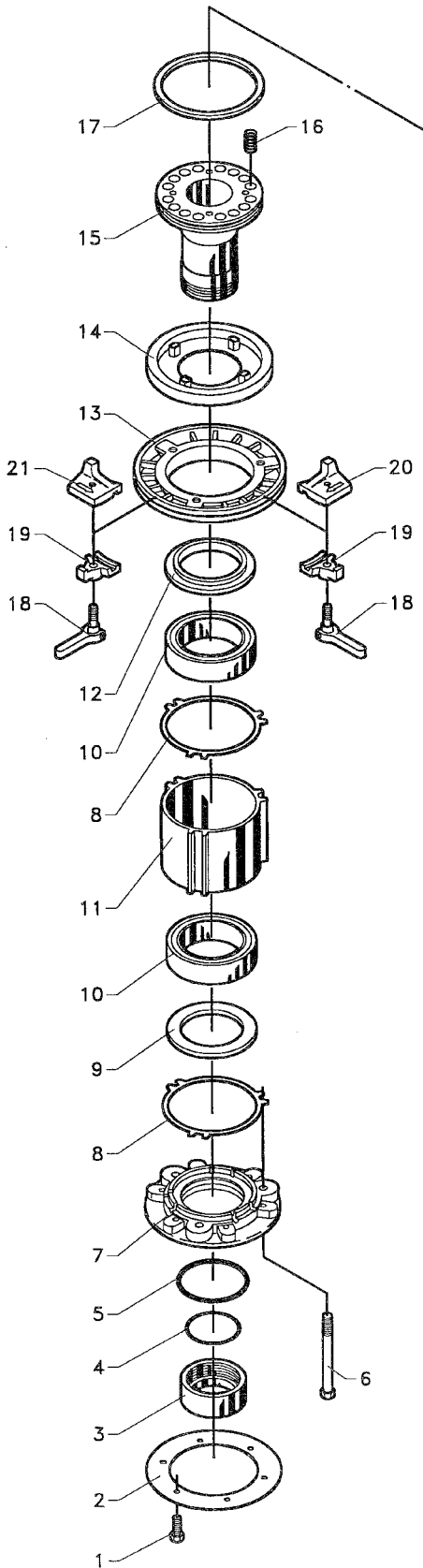

Item No.	Part No.	Qty	Description	Comments
42	778323-017	1	Retaining ring	
43	776045	1	Retaining ring	
44	776054	2	Ball bearing	
45	778326	1	Spacer pipe	
46	776048	1	Oil seal ring	
47	778394	1	Switch lever	
48	776064	1	Nut	
49	777029	1	Washer	
50	776714	2	Split pin	
51	778197	1	Bolt	
52	778282	1	Shaft	
53	778409	2	Flat washer	
54	778446	1	Pipe	
55	778470	1	Spring	
56	778417	1	Shaft	
57	778336	1	Washer	
58	776580	3	Stop pin	
59	778311	2	Screw	
60	778263	1	Cover	
61	778265	1	Gasket	
62	778323-004	1	Retaining ring	
63	778321	2	Bearing	
64	778281	1	Spacer pipe	
65	778317	1	Seal	
66	778193	1	Pin	
67	778320	1	Split pin	
68	778448	1	Plate	
69	778274	1	Shaft	
70	776931	1	Locking pin	
71	776089	2	Plug	
72	778497	1	Nozzle pipe	
73	776059	2	Bolt	
74	778511	1	Gasket	
75	778322	1	Split pin	
76	778277	1	Roller	
77	778276	1	Shaft	
78	778410	1	Arm trip lever	
79	778451	1	Complete switch	
80	778408	4	Bolt	
81	778460	1	Gasket	
82	778587	1	Jet pipe	

1

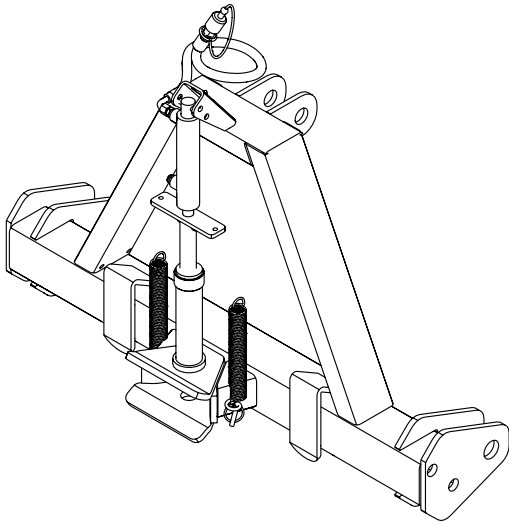

2

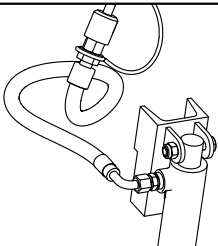
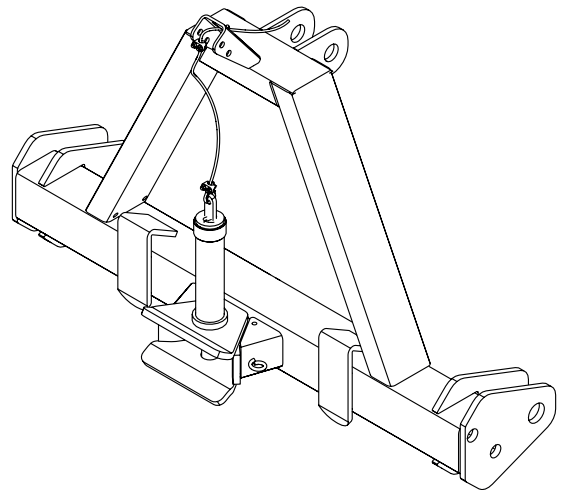

B2

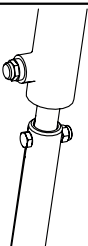

B1

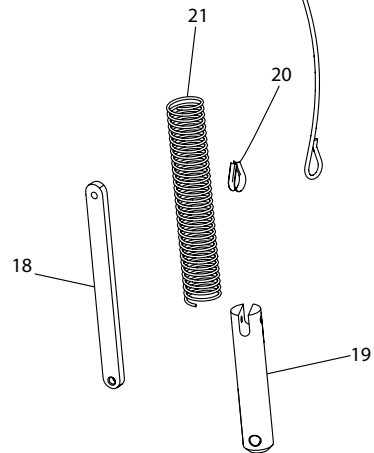
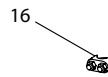
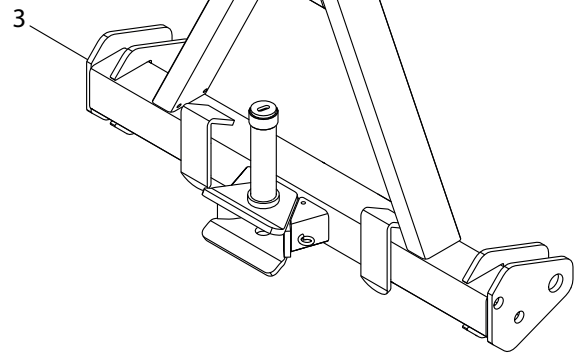
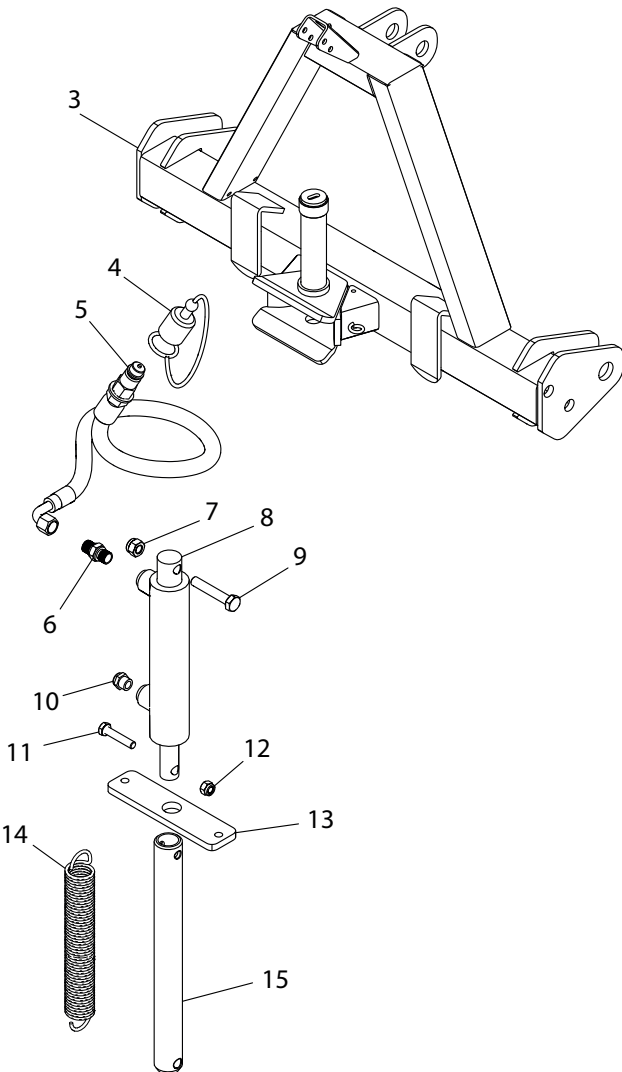

Item No.	Part No.	Qty	Description	Comments
1	1008280-4	1	A-frame Hydraulics Category 3	
1	1008280-3	1	A-frame Hydraulics Category 2	
2	1008280-5	1	A-frame Cable Category 2	
2	1008280-6	1	A-frame Cable Category 3	
3	2013387	1	A-frame Category 3	
3	2014300	1	A-frame Category 2	
4	801711	1	Plastic plug for male coupling	
5	1008288	1	Hydraulic hose for A-frame	
6	121001BP04	1	Nipple 1/4	
7	044010	1	M10 Lock nut	
8	1008287	1	Cylinder for A-frame	
9	021010055	1	M10 x 55 Steel bolt	
10	591575	1	Filter plug, Silencer	
11	022208040	1	M8 x 40 Set bolt	
12	044008	1	M8 Lock nut	
13	1008285	1	Hole plate for hydraulics	
14	761274	1	Spring	
15	1008283	1	Drawbar pin A-frame	
16	1562220206	1	Cable lock	
17	1008292	1	Cable with nylon for A-frame	
18	1008284	1	Arm for Drawbar pin	
19	1008282	1	Drawbar pin for A-frame	
20	761012-1	1	Cable thimbles	
21	1008290	1	Compression spring for A-frame	

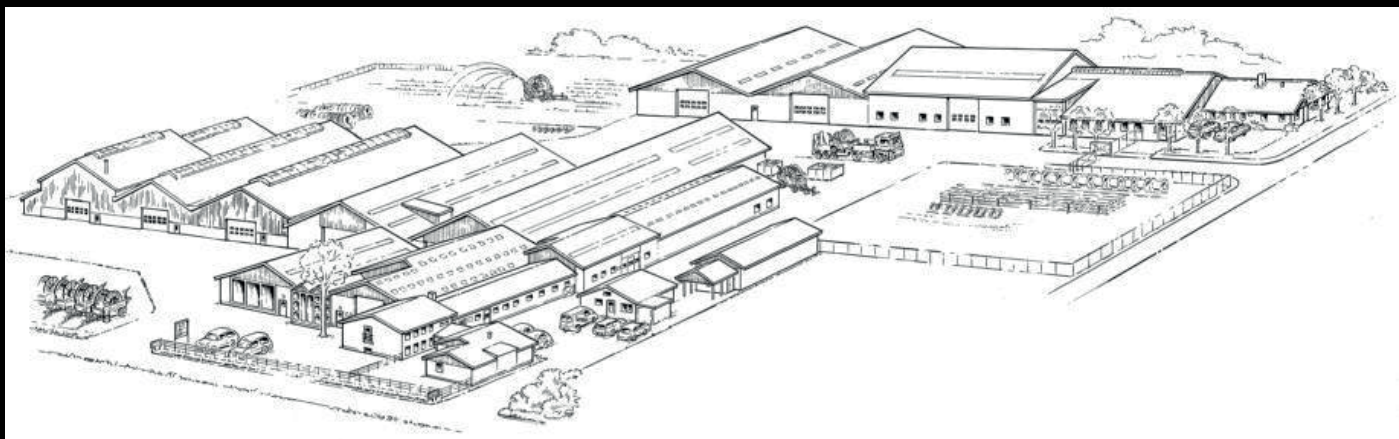

FASTERHOLT

**A/S FASTERHOLT MASKINFABRIK
EJSTRUPVEJ 22, DK-7330 BRANDE
DENMARK**

TEL.: +45 97 18 80 66 FAX: +45 97 18 80 40

E-MAIL: MAIL@FASTERHOLT.DK

www.fasterholt.dk