

INSTRUCTION

2-4-5 TT₂

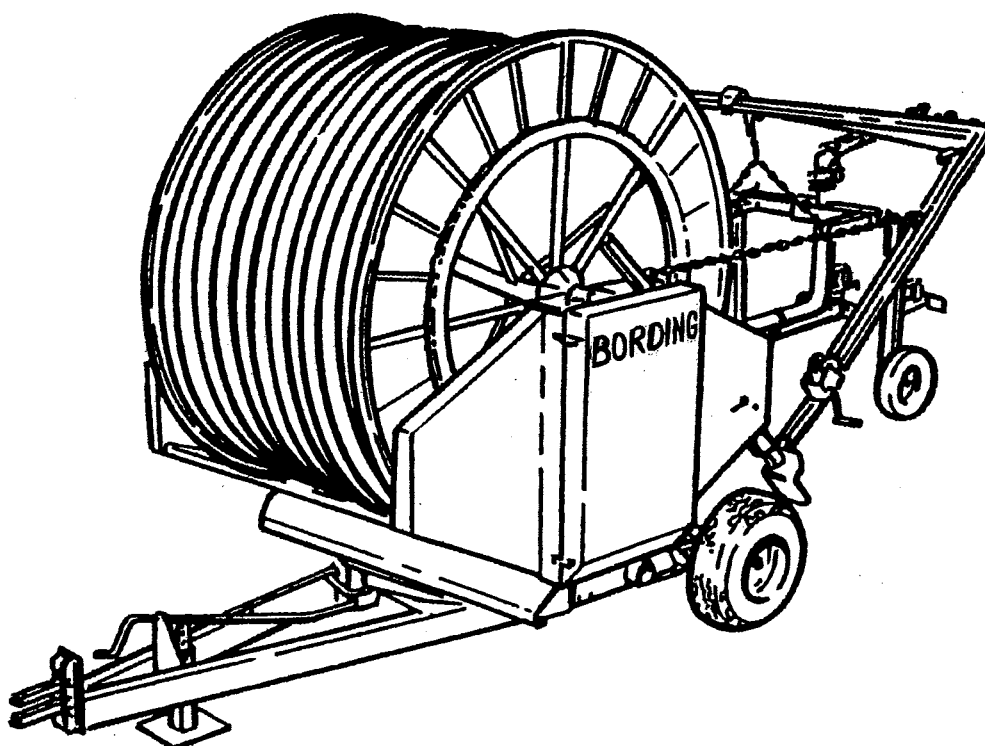

B
O
R
D
I
N
G

FASTERHOLT TM

Introduction

Bording Type 2-3-4-5 TT² Irrigation Machine.

The Bording type 2-3-4-5 TT² irrigation machine is of the hose reel type with coiling hose, which is pulled in during irrigation by means of a turbine. The hose drum is mounted on a turntable and the machine is fitted with a gun carriage lift, so the pull-out direction can be changed without moving the machine. The hose pull-in stops automatically when the gun carriage reaches the machine.

The machine can operate with automatic stop of the feed pump by high or low pressure. At stop by high pressure it must be ensured that the pump is stopped either by a high pressure switch or that it is able to discharge the water in another way, when the machine stops the irrigation. At stop by low pressure the pump must be stopped by a low pressure switch, which stops the pump when the pressure drops in the main supply line.

The attention is drawn the fact that it is a machine to irrigate fields in agriculture, horticulture, nurseries and similar, and it is supplied with water under high pressure as well as there is high pressure on the rain gun. This may cause person damages by incorrect operation, and therefore the stated warnings and safety instructions must be respected and followed carefully.

Please be careful that no unauthorized persons have access to the machine during operation.

In order to achieve the best possible benefit of the machine, it is important that the instruction manual is carefully observed. Only a few operations are necessary to operate the machine, and they are described in the manual in the correct order. After a few runs, the procedure will be a matter of routine, but the operating machine must always be inspected before leaving it to ensure all is well.

A check-list is enclosed this instruction manual to be examined by the service engineer together with the customer/user when starting up the new machine. If the check-list is not examined and signed, responsibility and guarantee will be withdrawn from A/S Bording Maskinfabrik.

Damage due to incorrect operation and/or to negligence is not covered by the guarantee.

Should you have any questions concerning the machine please contact your **BORDING** dealer.

Yours faithfully
A/S Bording Maskinfabrik

CONTENTS

Introduction	Page 1
Safety instruction	Page 3
View of the entire machine	Page 4
View of operating panel	Page 5
Working scope	Page 6
Transport	Page 6
Setting-up for irrigation	Page 6
Pulling out the hose	Page 6
Starting-up	Page 7
Amount of precipitation	Page 7
Adjustment of rain gun	Page 7
Automatic stop	Page 7
Manual stop	Page 7
Safety stop	Page 8
Supervision	Page 8
The PTO wind-in	Page 8
Gun carriage	Page 8
Maintenance	Page 9
Lubrication	Page 9
Annual maintenance	Page 9
Making ready for winter	Page 10
Fault location table	Page 11
Precipitation tables	Page 12
Pipe sketch (high/low pressure 3-4-5 TT ²)	Page 14

Safety instruction

General safety: To operate the irrigation machine, carefully read the instruction manual before operating the machine. Only well trained and qualified persons must operate the machine. Only one person (the operator) must stay at the machine during transport, setting-up and operation.

Definitions:

During transport: The machine is connected to a vehicle ready for transportation to the place of setting-up.

During setting-up: The machine is placed at the area to be irrigated and the hose is or has been pulled out and is ready to be supplied with water.

In operation: The machine is supplied with water under pressure, or the machine is operated by PTO.

Not in operation: There is no pressure or flow on the machine. There is no water supply connected to the machine. The machine is not operated by PTO.

When the machine is "In operation" (see definition) only the following functions must be carried out:

- * 1 Adjustment of the pull-in speed.
- * 2 Changing the gear, if this has been incorrectly adjusted.

Warning !



If there is tension in the hose when the engaging lever (clutch) is set to "Free", the hose drum can reverse with great force.

Staying on or under the machine during transport, setting-up and operation involves danger of one's life.

Be careful around actuator and other movable parts operated by electronic speed control. These continuously adjust the flow through the turbine and therefore may trap or crush arms, hands and fingers.

All other adjustments on the machine, gun carriage and gun must only be done, when the machines is "Not in operation".

Modification in construction must not be made without previous consultation with your dealer or A/S Bording Maskinfabrik.

In following the instruction manual are warnings that concern your safety. These are marked with the following symbol. This symbol is also found on the machine, where it means danger. Therefore be careful where this symbol is seen.



Observe this warning, when you see the symbol.

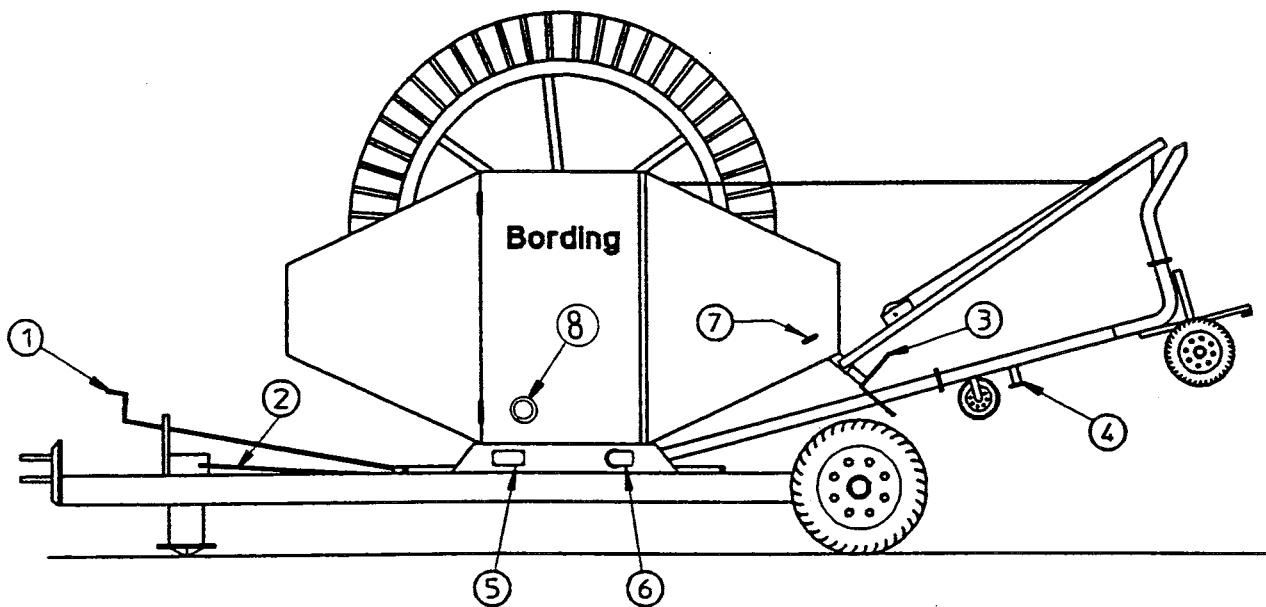

		2TT ²	3-4-5TT ²
Pos 1.....	Hand lever for turntables		x
Pos 2.....	Locking pawl for turntable	x	x
Pos 3.....	Supporting legs	x	x
Pos 4.....	Sluice valve		x
Pos 5.....	Water supply low-pressure stop		x
Pos 6.....	Water supply high-pressure stop		x
Pos 7.....	Handle for supporting legs		x
Pos 8.....	Water supply	x	

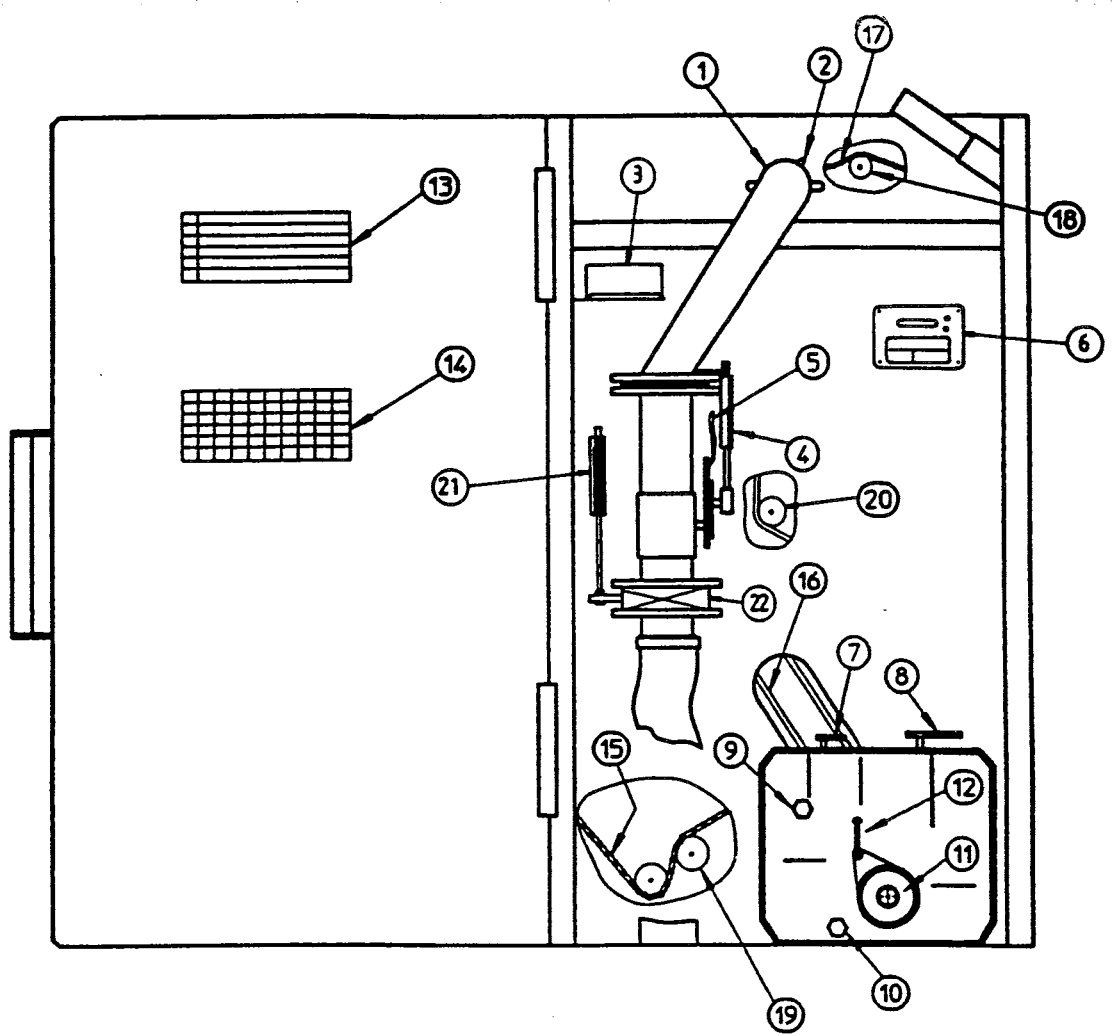

2TT² 3-4-5TT²

Pos 1.....	Sliding bush	X	X
Pos 2.....	Lubricating nipple at bush	X	X
Pos 3.....	Battery	X	X
Pos 4.....	Actuator	X	X
Pos 5.....	Safety wire	X	X
Pos 6.....	Best One	X	X
Pos 7.....	Gearshift lever	X	X
Pos 8.....	Engaging lever (clutch)	X	X
Pos 9.....	Level monitoring for oil	X	X
Pos 10.....	Draining off oil	X	X
Pos 11.....	PTO shaft (take-in)	X	X
Pos 12.....	Brake	X	X
Pos 13.....	Gear table	X	X
Pos 14.....	Precipitation table	X	X
Pos 15.....	Main chain	X	X
Pos 16.....	V-belt	X	X
Pos 17.....	Chain for hose guide	X	X
Pos 18.....	Chain adjuster hose guide	X	X
Pos 19.....	Chain adjuster main chain	X	X
Pos 20.....	V-belt adjuster	X	X
Pos 21.....	Actuator for stop valve	X	
Pos 22.....	Butterfly valve (stop valve)	X	

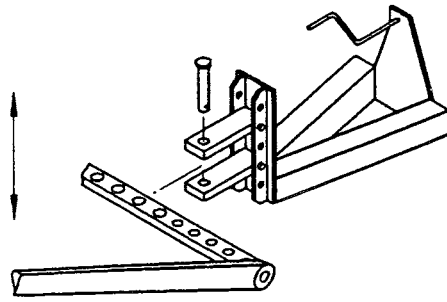

FIG 1

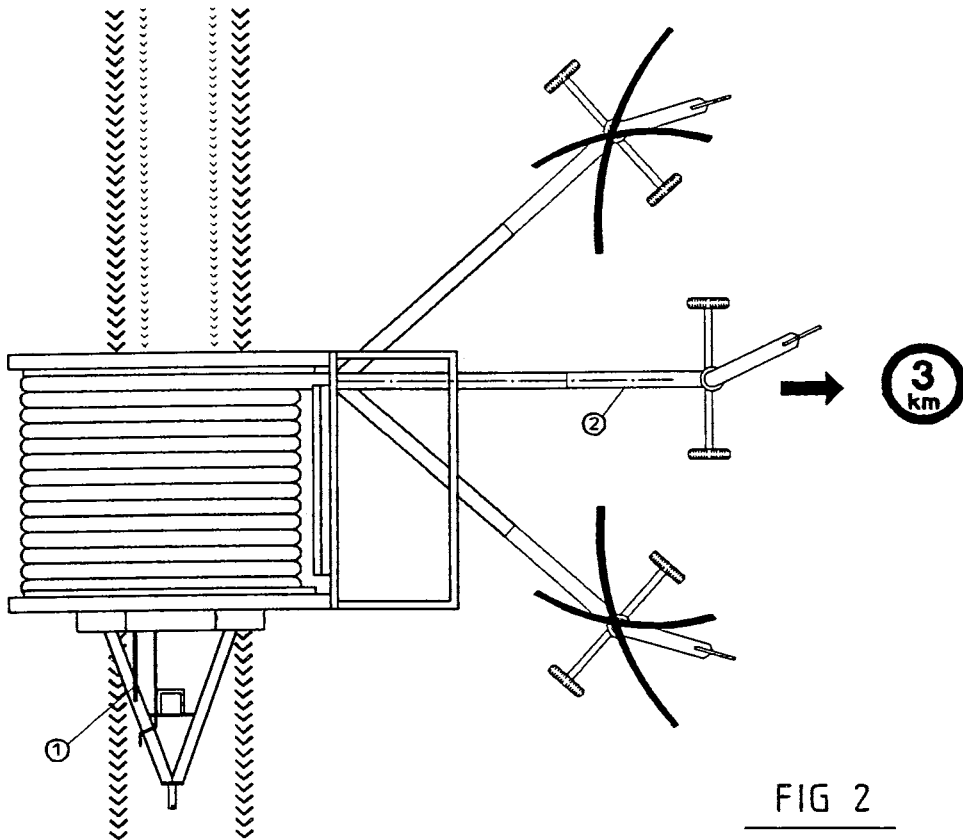

FIG 2

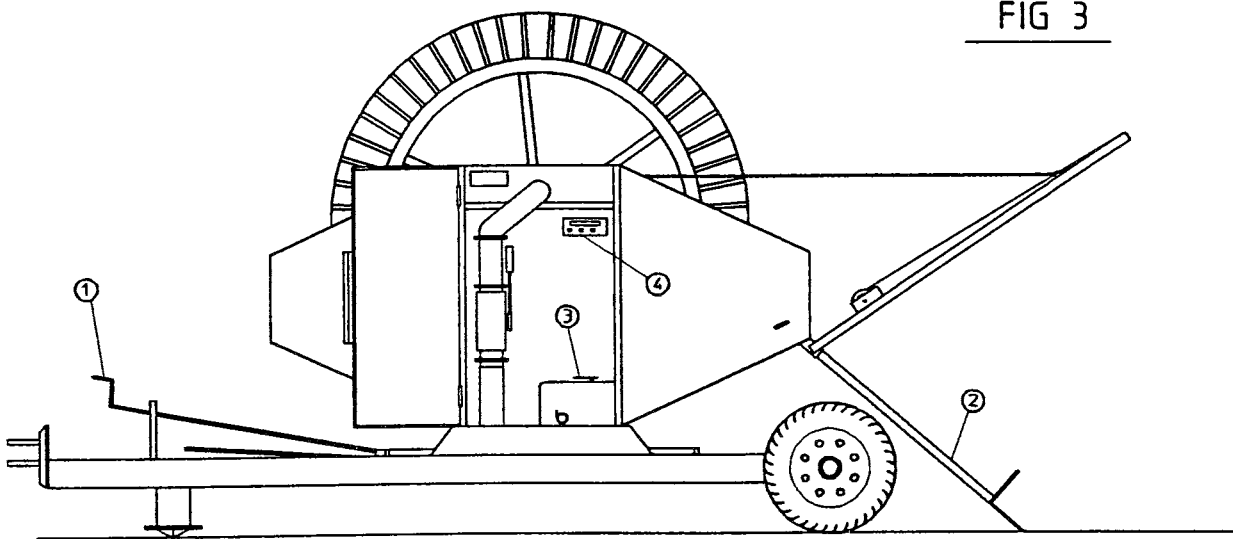

FIG 3

Working scope

The working scope of the machine is to spread water, sewage and other liquids. However, the contents of dry matter must not exceed 15%. No particles in the liquid must exceed 10 mm, as this will clog the turbine of the machine. The machine must be supplied with a maximum inlet pressure of 12 bars, but an advisable working pressure is 7-9 bars.

Transport

When the machine is to be moved or brought out into the field, it is connected to a toolbar in the three point linkage of the tractor, and the lift of the tractor is used for the lifting and lowering of the machine.

- * 1 The hose drum is turned so that the gun carriage faces backwards.
- * 2 The supporting legs must be in transport position.
- * 3 If the machine does not have brakes, the speed must not exceed 6 km/h (4 m.p.h.).

Note! If the machine is to be transported via public thoroughfare, the machine must have lights and markings installed.

Important! The engaging lever (clutch) must be engaged during transport to avoid loosening of the hose on the hose drum.

Setting-up for irrigation

- * 1 The machine is placed horizontally and straight out to the direction of pull-out.
- * 2 The field must be level for the first 10 m in the direction of pull-out.



Unauthorized persons are forbidden to be near the machine during the manoeuvring of the gun carriage and the machine.

Pulling out the hose

- * 1 Loosen the locking pawl by the cogwheel, (fig. 2, pos. 1).
- * 2 Turn the hose drum in the desired direction.
- * 3 Lock the locking pawl, (fig. 2, pos. 1)
- * 4 Lower the supporting legs and force them into the ground, (fig. 3, pos. 2). On type 3-4-5 TT² the supporting legs are fixed with the handle which is found in the door.
- * 5 Lower the gun carriage and disconnect it from the lift.
(On machines with hydraulic supporting legs the gun carriage is lowered automatically)
- * 6 Open the sluice valve on type 3-4-5 TT² under the gun carriage, (fig. 2, pos. 2)
- * 7 Push the engaging lever (clutch) into "FRI" ("FREE"), (fig. 3, pos. 3)
- * 8 Connect the gun carriage to the tractor and pull it out - max 3 km/h (2 m.p.h.).
- * 9 The feed hose should not be connected during pull-out.

If the water has not started to run out of the machine after approximately 10 metres, it may be profitable to suspend the pulling out of the hose for a moment before starting again.

Important! Make sure that there are at least 2 hose windings left on the hose drum, when the hose is being pulled out. If not, the hose coupling may be damaged when the hose is pulled in. In case of hilly terrain, where the machine can no longer be seen from the tractor, the operator must have an assistant to signal, when there are only two windings left on the drum.

Note! If the machine has been left to stand in the sun, or has been exposed to another kind of heat, the hose will be damaged, if it is pulled out. If the temperature of the hose exceeds 30°C, it must be cooled by the flow of water, before it is pulled out.

When the hose is being pulled out, it is important to avoid sudden stops, as this may cause the hose to become tangled on the drum.

If the hose works loose on the hose drum during the pull-out, the brake must be adjusted (Fig. 4, Pos. 2). If the hose is loose on the drum after the pull-out, it must be tightened up with the PTO crank found in the door. **Remember** to remove the PTO crank when the tightening has finished.

FIG 4

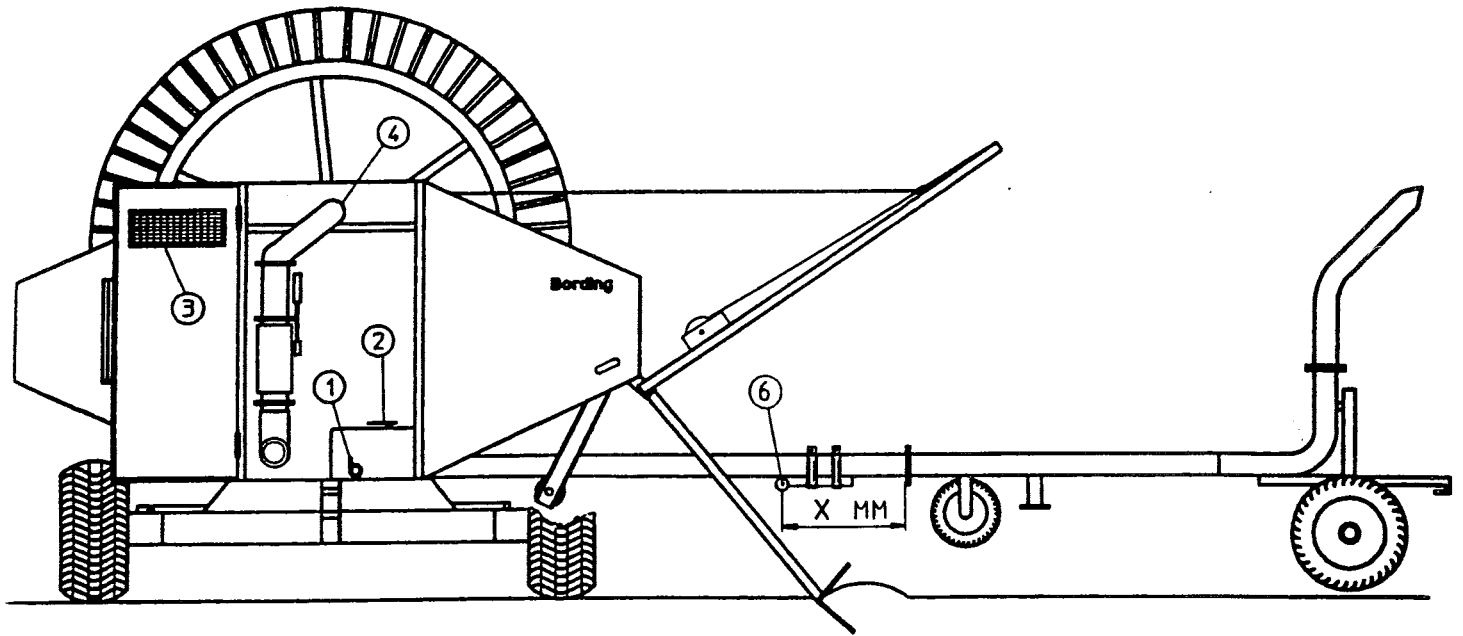

2TT₂ - X = 550 MM

3-4-5TT₂ - X = 1000 MM

POS 3

GEAR	SPEED M/H
1	7 - 20
2	15 - 45
3	25 - 65
4	40 - 100

Starting-up

Important before the machine is started!

If the machine has been placed in strong sunlight for quite a long time after the pull-out, and if the temperature is above 30gr. C, the hose must be cooled down before the pull-in may begin.

- * 1 Connect the feed hose.
 - * 2 Engage the engaging lever (clutch), (fig. 4, pos. 2).
 - * 3 Select the gear from the table which is found on the inside of the door, (fig. 4, pos. 3).
 - * 4 Determine the speed of pulling in on the computer by means of the arrow keys
(see paragraph under amount of precipitation).
 - * 5 Press start.
 - * 6 If pre-irrigation is wanted, press pre-irrigation (indicated in the display).
 - * 7 If post-irrigation is wanted, press post-irrigation (indicated in the display).
 - * 8 Open the hydrant and start the pump for water supply.
- See further under electronic speed control "Best-One"



Loitering is forbidden on and under the machine during operation

Amount of precipitation:

When the pull-in speed, type, size and pressure of the nozzle are known, readings of the amount of precipitation can be taken from the tables. The pressure of the nozzle can be read on the pressure gauge on the rain gun. The table shows the maximum effective spreading widths in calm weather. In windy weather these will drop about 10%.

Adjustment of rain gun

The best distribution pattern is obtained at a sector angle of approximately 200°, which means that the rain gun operates over an angle of 200°.

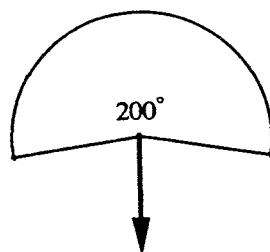

Pull-in direction

The pressure at the rain gun ought to be 3,5 - 4,5 bars depending on the amount of water. At a large amount of water the pressure ought to be higher.

Automatic stop

The machine stops automatically when the gun carriage is pulled in next to the machine. The machine can operate with automatic stop of the feed-pump by high or low pressure. At stop by high pressure it must be ensured that the pump is stopped either by a high pressure switch or that it is able to discharge the water in another way, when the machine stops the irrigation. At stop by low pressure the pump must be stopped by a low pressure switch, which stops the pump when the pressure drops in the main supply line. The stop face is fitted on the hose with 2 clips (fig. 4, pos. 6).

Manual stop

The machine can be stopped either on the pump or by pressing "stop" on the computer. If the hose is to be pulled in after stop, see "PTO wind-in".

FIG 8

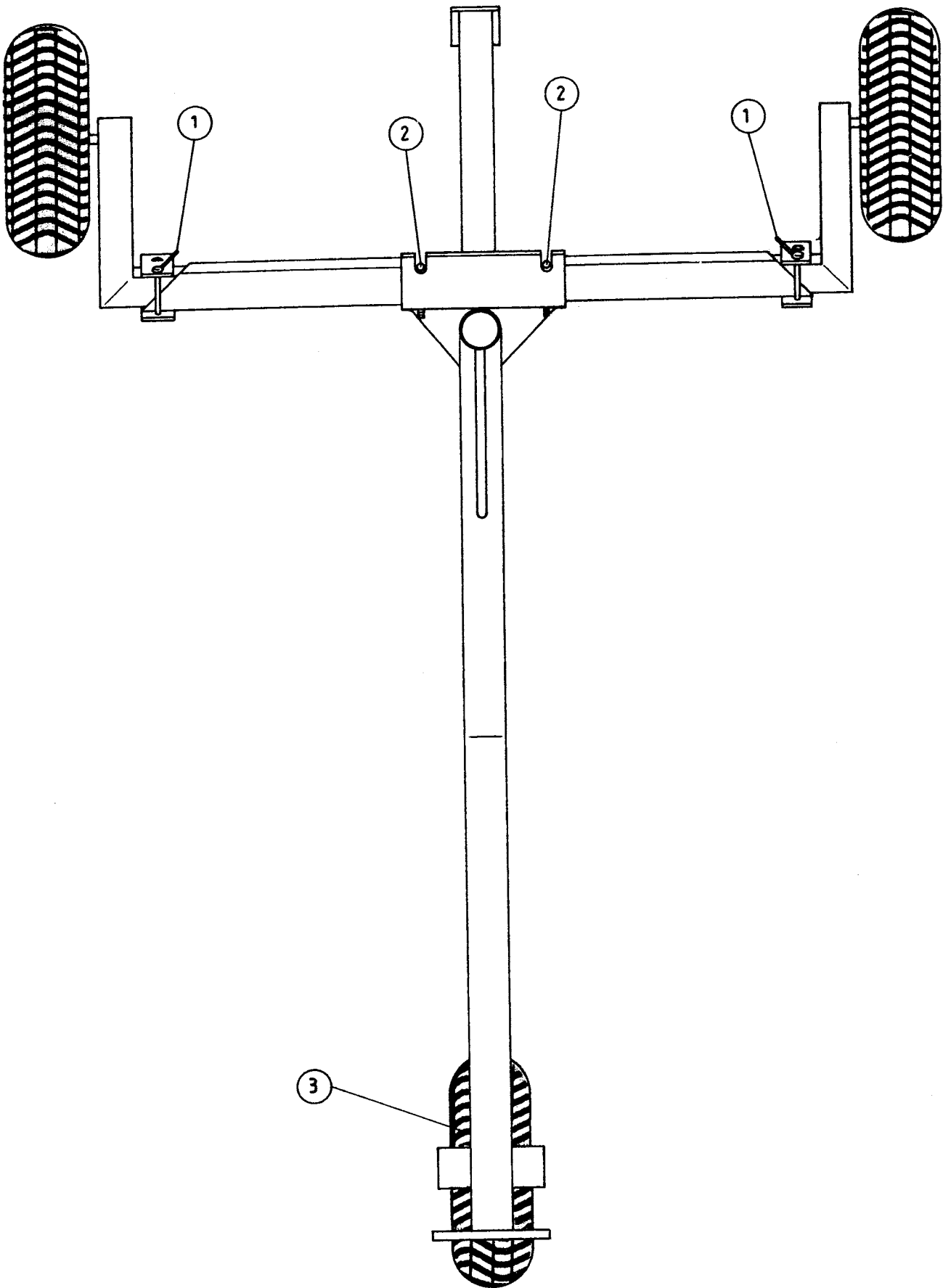

Safety stop

The safety bar on the pull-in side of the machine (above the hose guide) ensures that the machine is stopped in case of incorrect winding of the hose. The safety wire ensures that the machine is stopped in case of computer failure. The safety bar is adjusted until it is 1 cm from the hose drum. The wire is adjusted so it is tight, when the 3-way valve is fully opened (max. pull-in speed), but make sure it is able to stop the pull-in before the stop system is fully activated.

Important! Check that the safety bar and the wire is adjusted correct when starting up the new machine and check frequently during the season.

Supervision

By way of supervision, the computer ensures that the machine is stopped by high or low pressure, if the pull-in stops at the incorrect time.

- i.e.:
- * 1 The machine is not in gear.
 - * 2 There are foreign matters in the turbine.
 - * 3 The V-belt is too slack.

PTO wind-in

The machine is fitted with a PTO wind-in, which can be used for manual winding of the hose if the irrigation is stopped before the gun carriage is next to the machine. The PTO wind-in is connected to the tractor through a PTO shaft, (fig. 9).

- * 1 The engaging lever (clutch) must be disengaged before the wind-in commences.
- * 2 Apply the hand brake of the tractor.
- * 3 Maximum PTO rotations 200 rpm.
- * 4 Stop the PTO wind-in about 2 m before the gun carriage is next to the machine, and use the PTO crank (which is placed in the door) for the last distance.

Important!

- * The machine must be under supervision when the hose is being wound on the drum by the PTO wind-in.
- * The PTO shaft must not be on the machine when the hose is being pulled out, or when the machine is in operation.
- * Dismantle the PTO crank during operation.



No loitering on and under the machine during operation.

If the machine has been stopped during pull-in there is tension in the hose, and the hose drum can reverse with great force, when the engaging lever (clutch) is disengaged.

Gun carriage

The wheel spacing on the gun carriage may be adjusted by loosening the clamp handles (fig. 8, pos. 1) and by moving the legs to the required width. The spacing ought to be adjusted to fit with the tractor, or if row crops are irrigated to fit with the crop spacing. Further more the gun carriage can be displaced to one side (fig. 8, pos. 2).

If the gun carriage does not follow the same track during pull-in, the centre-bolt in the steering wheel (fig. 8, pos. 3) may be loosened and the wheel axle may be adjusted backwards or forwards in one of the sides to allow alignment.

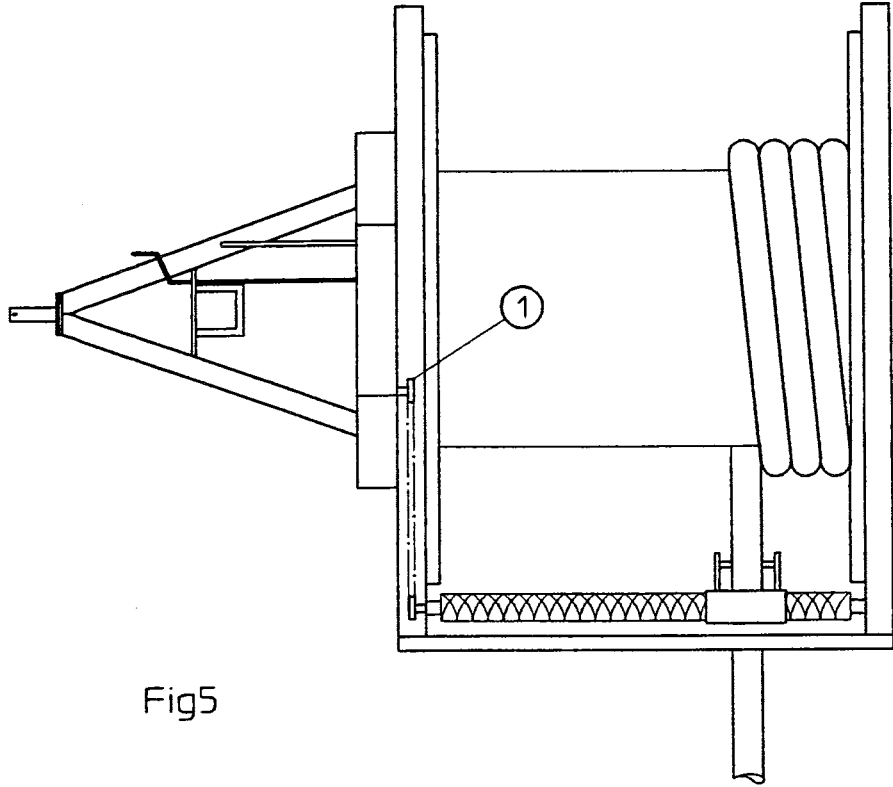

Fig5

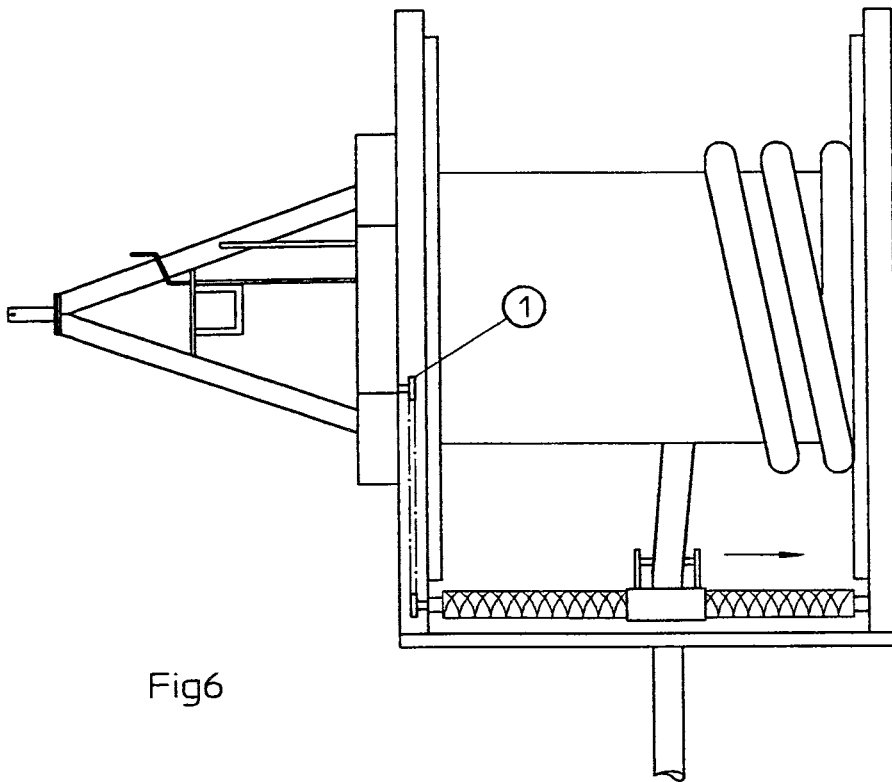

Fig6

Maintenance

Important! After the first 25 working hours:

- * 1 Tighten up the machine.
- * 2 Adjust chains and V-belt.
- * 3 The hose guide is adjusted

After 25 working hours, it is often required to adjust the hose guide. In order to decide whether the hose guide needs adjustment check if the hose guide places the hose close to the previous hose winding (see fig. 5). If shown as in (fig. 6), it is necessary to adjust the hose guide.

Adjustment of hose guide: Stop the machine, loosen the chain adjuster (pos. 1), and disengage the chain on the chain wheel. The chain can now be pulled backwards or forwards manually. Thus, the hose guide will move to one side or the other. Move the hose guide in this way so that the hose, which is engaged, overlaps the wound hose with 5-10 mm. When this stage has been obtained, engage the chain once again and tighten up the chain. Let the drum revolve a couple of times to check if the hose guide has been adjusted correctly.

Lubrication (after 25 working hours) and subsequently once a week

- * 1 Sliding bush on the inlet pipe of the hose drum (fig. 4, pos. 4).
- * 2 Cross track shaft (endless screw).
- * 3 Main bearings by the hose reel.
- * 4 Chains are lubricated with water-repelling oil.
- * 5 Wheels of the gun carriage.
- * 6 Rotary rim.

For the lubrication of the above parts, molycote grease is recommended.

Note! The sliding bush on the input bush of the hose drum must only be lubricated until a faint increase of pressure is obtained in the grease gun.

Annual maintenance

- * 1 Sliding bush on the inlet pipe of the hose drum (fig. 4, pos. 4).
- * 2 Cross track shaft (endless screw).
- * 3 Main bearings by the hose reel.
- * 4 Chains are lubricated with water-repelling oil.
- * 5 Wheels of the machine and gun carriage.
- * 6 Rotary rim.

For the lubrication of the above parts, molycote grease is recommended.

Note! The sliding bush on the input bush of the hose drum must only be lubricated until a faint increase of pressure is obtained in the grease gun.

Lubricate the throttle in the 3-way valve at the turbine with water-repelling grease (KLÜBER NBU 30 PTM).

Change the oil of the gearbox. Oiltype Castrol EPX 80/90 gear oil or similar.

Check the air pressure of the wheels:	Machine	= 38 p.s.i. - 2.75 bars
	Gun carriage	= 14 p.s.i. - 1.00 bar

Making ready for winter

Before the frost arrives, the machine must be made ready for winter. Contact your BORDING dealer concerning a winter service visit. Thus you will avoid undue operation stoppages during the season.

Making ready includes the following points:

Empty the hose of water, either by means of compressed air or by pulling the hose out into the field, emptying it of water, and pulling it back with the PTO wind-in.

The gun carriage must be disconnected from the hose during wind-in.

The hose must not be wound up tightly, as the hose is to work at different temperatures. This is obtained by loosening the hose a little on each layer with the PTO crank when winding up.

Clean the gun and spray it with acid-free oil.

Lubricate and adjust the chains.

Check the air pressure of the wheels:	Machine	= 38 p.s.i. - 2.75 bars
	Gun carriage	= 14 p.s.i. - 1.00 bar

Lubricate the throttle in the 3-way valve at the turbine.

Lubricate all movable parts with rust-preventing oil (Lps oil).

The battery must be kept in a dry and non-freezing place.

Important! Avoid high-pressure cleaning of the computer, the electric components and the packing boxes by the bearings.

Fault Location table:

Fault	Cause	Solution
Hose reel stop	Foreign matter in turbine	Dismantle front cover from turbine and clean it. Never turn the turbine forcibly.
	Engaging lever not in mesh	Engage it
	Gear not in mesh	Engage it
	Computer failure	Check computer
	3-way valve is stuck	Check 3-way valve
Computer failure	Battery is flat	Charge or exchange it
	Sensor at stop bar activated	Adjust or exchange it
	Control fault in computer	Contact dealer
Actuator not running	Throttle in the 3-way valve at turbine is stuck	Clean and lubricate the throttle
	Actuator not working	Computer failure or exchange actuator
Incorrect winding	Hose guide out of adjustment	Adjust hose guide
	Too much hose on the drum	Check hose length
Incorrect pull-out (hose is slack)	Brake is slack	Adjust brake
	Too quick stop when pulling out	Decrease speed over a longish distance
Hose guide does not move	Chain off or snapped	Repair or exchange it
	Guide pin defective	Exchange it
Gun not working	Too low pressure	Increase pressure or change to smaller nozzle
	Sector guide destroyed	Exchange or repair stop release
	Wrong nozzle size	Exchange nozzle

Precipitation Nelson SR100 and SR150 with 21° trajectory angle

Nozzle size, aluminium taper bore	0.6° - 15.2 mm		0.7° - 17.8 mm		0.8° - 20.3 mm		0.9° - 22.9 mm		1.0° - 25.4 mm		1.1° - 27.9 mm		1.2° - 30.5 mm		1.3° - 33.0 mm	
	0.712° - 18.1 mm	0.812° - 20.6 mm	0.895° - 22.7 mm	1.00° - 27.4 mm	1.08° - 30.0 mm	1.18° - 32.0 mm	1.26° - 34.0 mm	1.34° - 36.0 mm	1.41° - 38.0 mm	1.49° - 40.0 mm	1.57° - 42.0 mm	1.65° - 44.0 mm	1.73° - 46.0 mm	1.81° - 48.0 mm	1.89° - 50.0 mm	1.97° - 52.0 mm
Nozzle size, ring nozzles SR100	3	4	5	6	7	8	9	10	11	12	13	14	15	16	17	18
Nozzle size, ring nozzles SR 150	3	4	5	6	7	8	9	10	11	12	13	14	15	16	17	18
Nozzle pressure, bars	15.6	18.0	20.0	21.0	24.5	27.4	31.2	34.8	38.2	40.4	45.2	49.6	53.0	55.8	58.0	60.0
Flow-rate, m ³ /h	54	58	63	67	74	77	82	88	94	99	105	110	115	120	125	130
Max. effective irrigation width, m	5	5.8	6.2	6.5	7.0	7.4	7.7	8.2	8.8	9.4	9.9	10.5	11.0	11.5	12.0	12.5
Pull-in speed, m/h	6	4.8	5.2	5.3	5.8	6.2	6.5	7.0	7.4	7.7	8.2	8.8	9.4	9.9	10.5	11.0
8	3.6	3.9	4.0	4.6	4.9	4.9	5.8	5.9	6.5	6.8	7.4	8.0	8.5	9.0	9.5	10.0
10	2.9	3.1	3.2	3.7	4.0	3.9	4.7	4.7	5.0	5.5	5.8	6.0	6.5	6.8	7.2	7.5
12	2.4	2.6	2.6	3.1	3.3	3.3	3.9	3.9	4.1	4.6	4.8	5.0	5.3	5.5	5.8	6.0
15	1.9	2.1	2.1	2.5	2.5	2.5	3.1	3.1	3.3	3.7	3.9	4.0	4.6	4.6	4.8	5.1
20	1.4	1.6	1.6	1.8	2.0	2.0	2.3	2.4	2.5	2.8	2.9	3.0	3.4	3.5	3.6	3.9
25	1.2	1.2	1.3	1.5	1.6	1.6	1.9	1.9	2.0	2.2	2.3	2.4	2.7	2.7	2.9	3.1
30	1.0	1.0	1.1	1.2	1.3	1.3	1.6	1.6	1.7	1.8	1.9	2.0	2.1	2.2	2.3	2.4
40	0.8	0.8	0.9	0.9	1.0	1.0	1.2	1.2	1.2	1.4	1.4	1.5	1.6	1.6	1.7	1.8
50	0.7	0.7	0.8	0.8	0.9	0.9	1.0	1.1	1.1	1.2	1.2	1.3	1.3	1.4	1.4	1.5
60	0.6	0.6	0.7	0.7	0.8	0.8	0.9	1.0	1.0	1.1	1.1	1.2	1.2	1.3	1.3	1.4
80	0.5	0.5	0.6	0.6	0.7	0.7	0.8	0.9	0.9	1.0	1.0	1.1	1.1	1.1	1.2	1.2
250 m	1.4	1.5	1.6	1.4	1.6	1.8	1.7	1.9	1.9	2.1	2.2	2.1	2.2	2.4	2.5	2.6
300 m	1.6	1.7	1.9	1.7	1.9	2.1	2.0	2.2	2.3	2.5	2.7	2.5	2.7	2.8	3.0	3.1
350 m	1.9	2.0	2.2	2.0	2.2	2.5	2.3	2.6	2.7	2.9	3.1	2.9	3.1	3.3	3.4	3.6
400 m	2.2	2.3	2.5	2.3	2.5	2.8	2.7	3.0	3.1	3.3	3.4	3.6	3.4	3.6	3.8	4.1
450 m	2.4	2.6	2.8	2.6	2.8	3.2	3.0	3.3	3.5	3.7	3.8	4.0	3.8	4.0	4.2	4.6
500 m	2.7	2.9	3.2	2.9	3.1	3.5	3.4	3.7	3.9	4.1	4.2	4.5	4.2	4.5	4.7	5.2

The table shows precipitation in mm

Precipitation Rain Bird SR 2003 and SR 1005 with 23° trajectory angle

Nozzle size, PVC taper bore	0.6" - 15.2 mm		0.7" - 17.8 mm		0.8" - 20.3 mm		0.9" - 22.9 mm		1.0" - 25.4 mm		1.1" - 27.9 mm		1.2" - 30.5 mm											
	3	4	5	6	4	5	6	4	5	6	4	5	6	4	5	6								
Nozzle size, aluminium taper bore	15,8	18,1	20,1	21,3	24,4	27,2	31,8	35,4	38,7	40,8	45,4	49,7	50,4	56,1	61,5	61,7	68,6	75,5	73,3	81,8	90,0	86,8	97,0	106
Nozzle size, ring nozzles	3	4	5	3	4	5	4	5	6	4	5	6	4	5	6	4	5	6	4	5	6	4	5	6
Nozzle pressure, bars	15,8	18,1	20,1	21,3	24,4	27,2	31,8	35,4	38,7	40,8	45,4	49,7	50,4	56,1	61,5	61,7	68,6	75,5	73,3	81,8	90,0	86,8	97,0	106
Flow-rate, m ³ /h	53	60	65	56	64	70	68	75	79	75	82	87	81	88	93	87	93	98	91	98	103	94	102	108
Max. effective irrigation width, m	5	60	60																					
Pull-in speed, m/h	6	50	50	52																				
	8	37	38	39	48	48	49	58	59															
	10	30	30	31	38	38	39	47	47	49	54	55	57											
	12	25	25	26	32	32	32	39	39	41	45	46	48	52	53	55	59							
	15	20	20	21	25	25	25	31	31	33	36	37	38	16	43	44	47	49	51	54	56	58		
	20	15	15	15	19	19	19	23	24	24	27	28	29	31	32	33	35	37	39	40	42	44	46	48
	25	12	12	12	15	15	16	19	19	20	22	22	23	25	26	26	28	30	31	32	33	35	37	38
	30	10	10	10	13	13	13	16	16	16	18	18	19	21	21	22	24	25	26	27	28	29	31	32
	40				10	10	10	12	12	12	14	14	14	16	16	17	18	18	19	20	21	22	23	24
	50				10	10	10	12	12	12	14	14	14	16	16	17	18	18	19	20	21	22	23	24
	60				10	10	10	11	11	11	11	11	11	12	13	13	14	15	15	16	17	17	18	19
	80																							
	250 m	1,3	1,5	1,6	1,4	1,6	1,8	1,7	1,9	2,0	1,9	2,1	2,2	2,0	2,2	2,3	2,2	2,3	2,5	2,3	2,5	2,6	2,4	2,6
	300 m	1,6	1,8	2,0	1,7	1,9	2,1	2,0	2,3	2,4	2,3	2,5	2,6	2,4	2,6	2,8	2,6	2,8	2,9	2,7	2,9	3,1	2,8	3,1
	350 m	1,9	2,1	2,3	2,0	2,2	2,5	2,4	2,6	2,8	2,6	2,9	3,0	2,8	3,1	3,3	3,0	3,3	3,4	3,2	3,4	3,6	3,3	3,6
	400 m	2,1	2,4	2,6	2,2	2,6	2,8	2,7	3,0	3,2	3,0	3,3	3,5	3,2	3,5	3,7	3,5	3,7	3,9	3,6	3,9	4,1	3,8	4,1
	450 m	2,4	2,7	2,9	2,5	2,9	3,2	3,1	3,4	3,6	3,4	3,7	3,9	3,6	4,0	4,2	3,9	4,2	4,4	4,1	4,4	4,6	4,2	4,6
	500 m	2,7	3,0	3,3	2,8	3,2	3,5	3,4	3,8	4,0	3,8	4,1	4,4	4,1	4,4	4,7	4,4	4,7	4,9	4,6	4,9	5,2	4,7	5,1

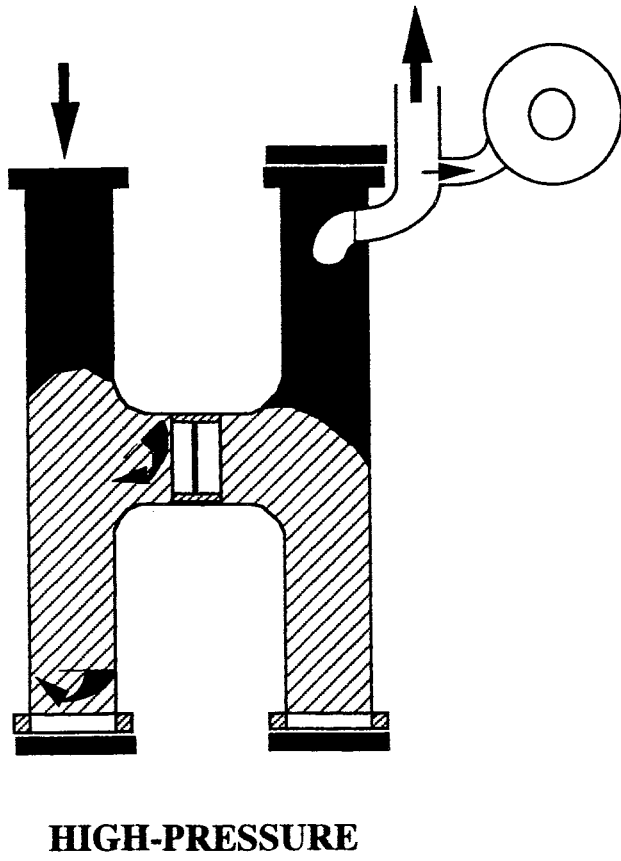
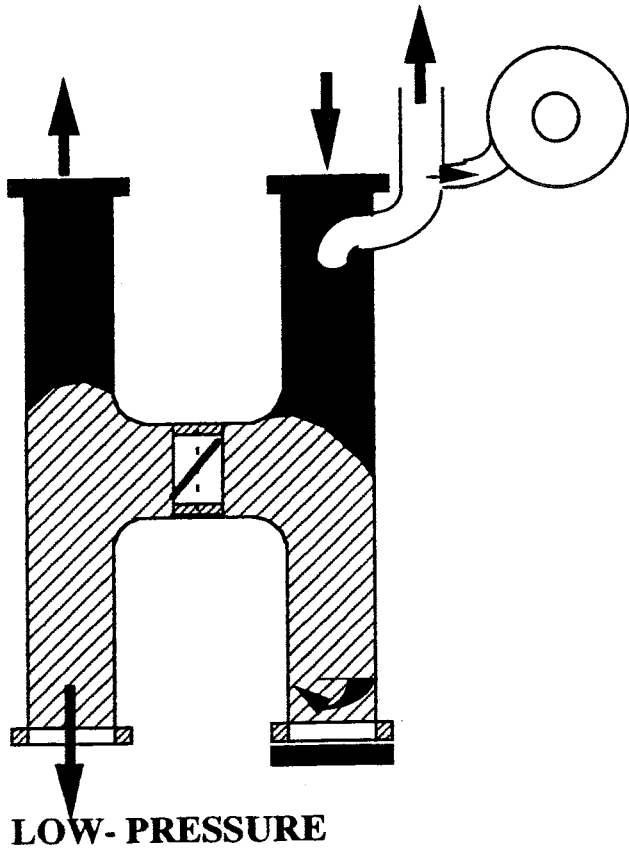

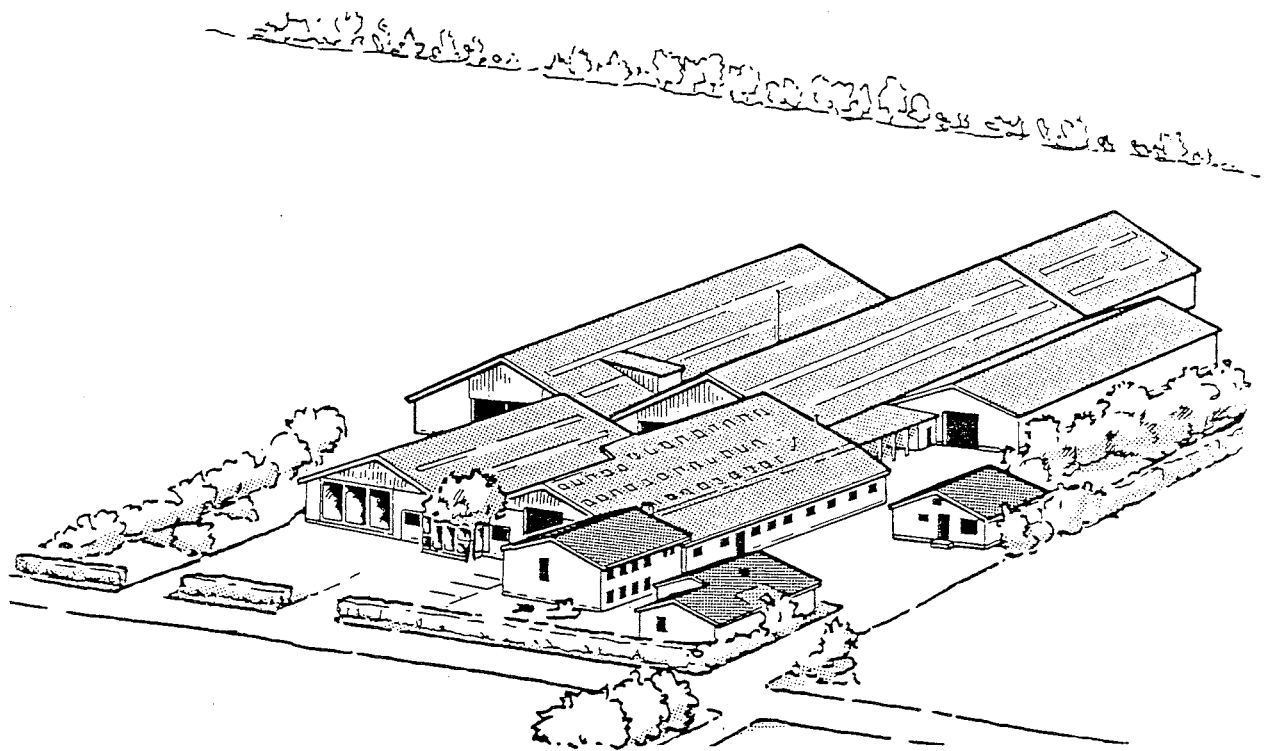

TM

FASTERHOLT

A/S FASTERHOLT MASKINFABRIK

EJSTRUPVEJ 22, DK 7330, BRANDE, DENMARK TLF+45 97188066 FAX +45 97188040
E-MAIL: MAIL@FASTERHOLT.DK WWW.FASTERHOLT.DK